

RADIO FLYER

3-in-1 Tailgater Wagon with Canopy

model/modèle/modelo #3963

For ages over 1 1/2 years.

Pur les enfants âgés de plus d'un et demie.

Para niños de más de 18 meses.



Register this product at www.radioflyer.com/register for a chance to win a Free Radio Flyer product! (One winner selected every month!)

Thank you for your purchase. If you have any questions or comments, please visit the customer service section of our website:

Merci d'avoir acheté notre produit. Si vous avez des questions ou commentaires, veuillez référer notre site web dans la section de service à la clientèle:

Gracias por su compra. Si tiene preguntas o comentarios por favor visite la sección, servicio al cliente de nuestro website:

www.radioflyer.com

Or phone / ou composez le / o llame al 1-800-621-7613

Available weekdays 8:00 a.m. to 5:00 p.m. CST.

Please keep this sheet for future reference.

Disponible sur semaine de 8:00 heures à 17:00 heures.

Veillez garder cette feuille comme référence.

De lunes a viernes de 8:00 a.m. a 5:00 p.m. CST.

Por favor retenga esta copia para futura referencia.

Radio Flyer Inc. / 6515 West Grand Ave. / Chicago, IL 60707

phone: 1-800-621-7613

The Original Little Red Wagon™ - Since 1917

1

Required:
Nécessaire:
Requeridas:



2

303196(x1)

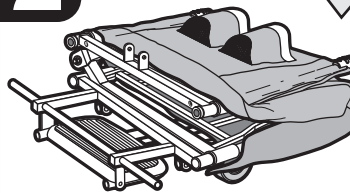

303228(x2)

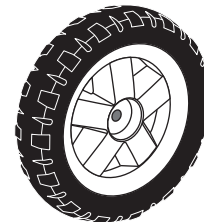

303226(x1)

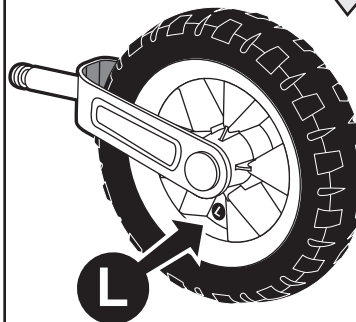

303227(x1)

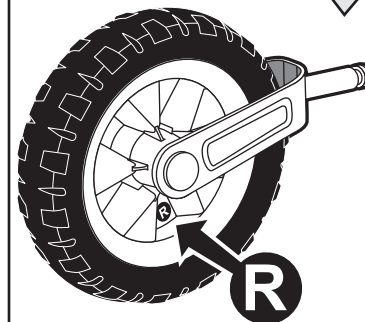

303230 (x1)

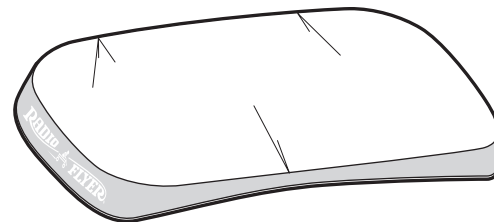

303351 (x1)

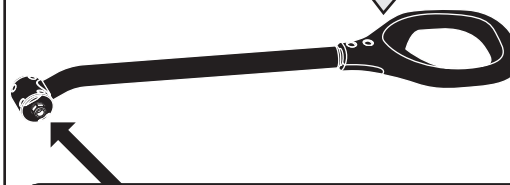

101645 (x1)

M6

300324 (x1)

100132 (x1)

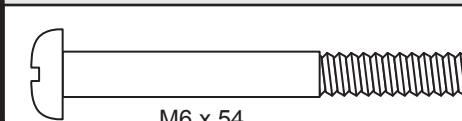

M6 x 54



M6
NYLOC

3

103192 (x2)

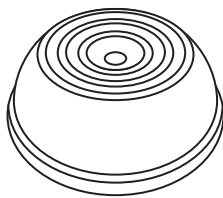

- If you find extra hardware items, please dispose of them and keep them away from small children.
- Si vous avez de éléments an surplus, rangez-les dans un endroit sur, a l'abri des bambins.
- Deshacerse de la ferreteria que le sobre, manteniéndolo fuera del alcance de los niños.

4 **WARNING:**

ADULT ASSEMBLY REQUIRED.

Choking hazard to children under the age of 3 years – contains small parts prior to assembly. All fasteners should be fully tightened.

Please keep instructions for future reference.

AVERTISSEMENT:

ASSEMBLAGE REQUIS PAR ADULTE.

Risque d'étouffement pour le enfants de moins de trois ans – Contient des pièces de petite taille avant assemblage. Toutes les attaches devraient être bien serrées.

Veillez garder les instructions comme référence aux besoins.

ADVERTENCIA:

MONTAJE REQUERIDO POR ADULTOS.

Peligro de asfixia an niños menores de 3 años - contiene piezas pequeñas antes del montaje. Todos los seguros deben ser apretado s completamente.

Mantenga por favor las instrucciones para la referencia futura.

5

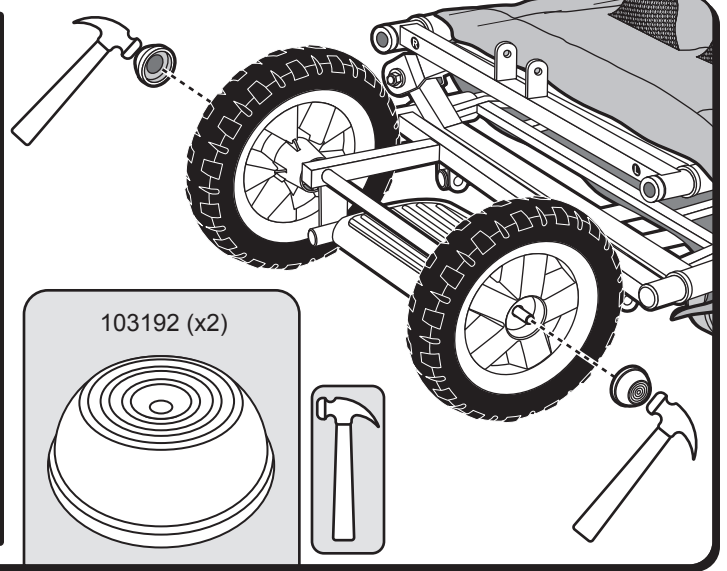
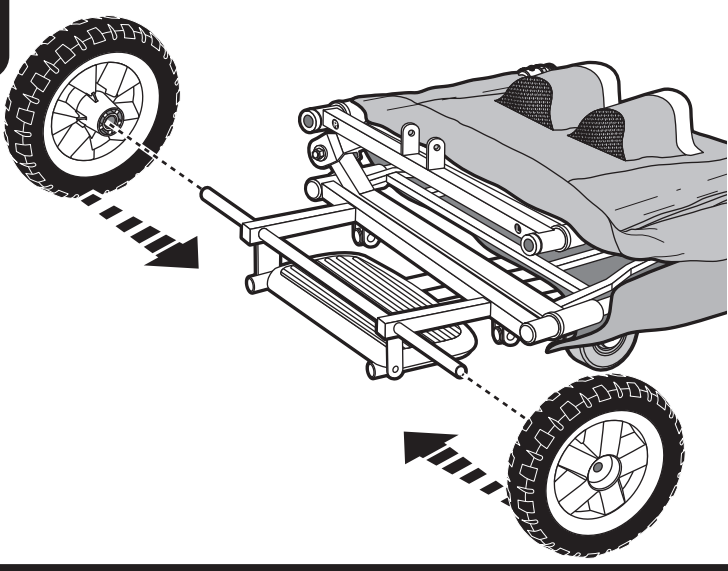

6

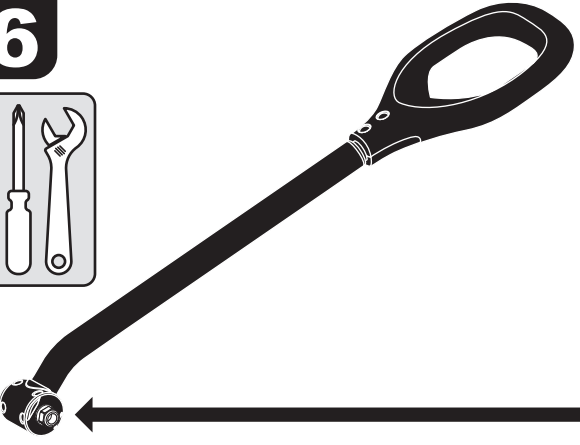

- Unscrew
- Dévisser
- Destornille

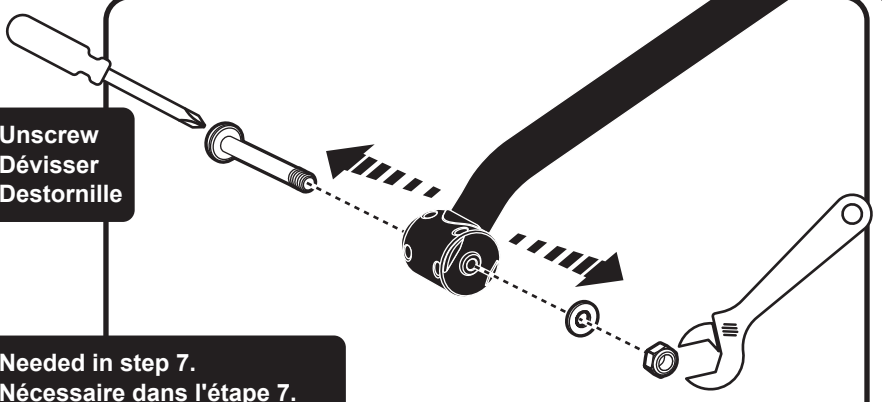

- Needed in step 7.
- Nécessaire dans l'étape 7.
- Se necesita en el paso 7.

7

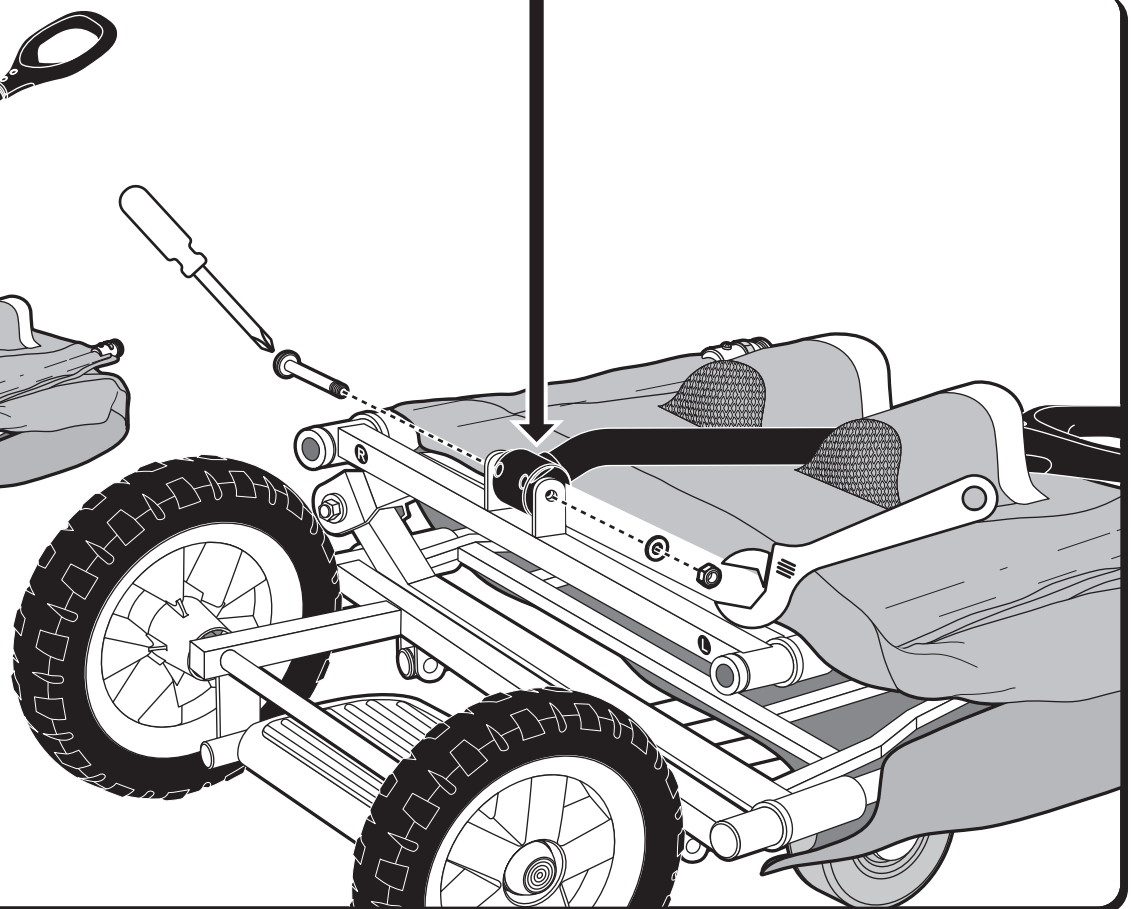
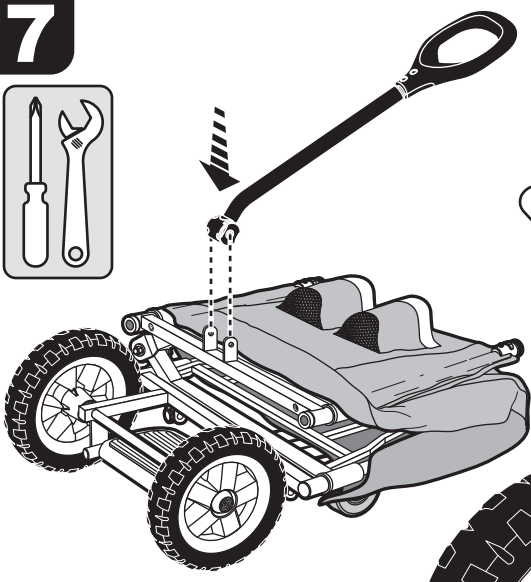

8

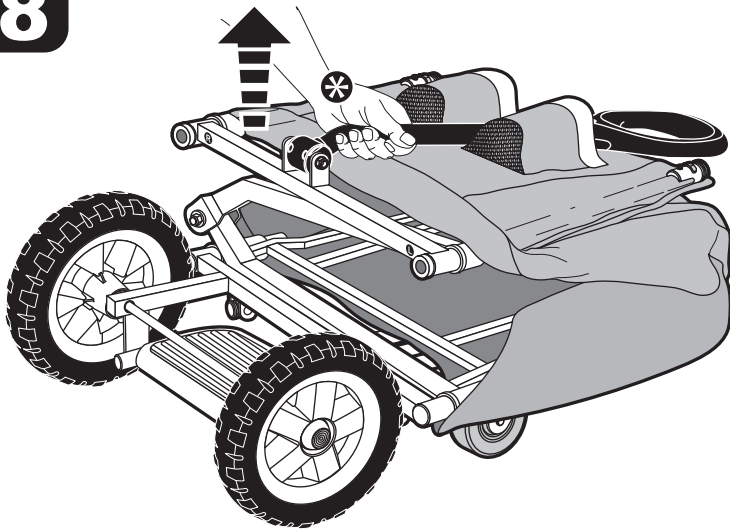

- ⊗ Lift slightly.
- ⊗ Lever légèrement.
- ⊗ Levantar ligeramente.

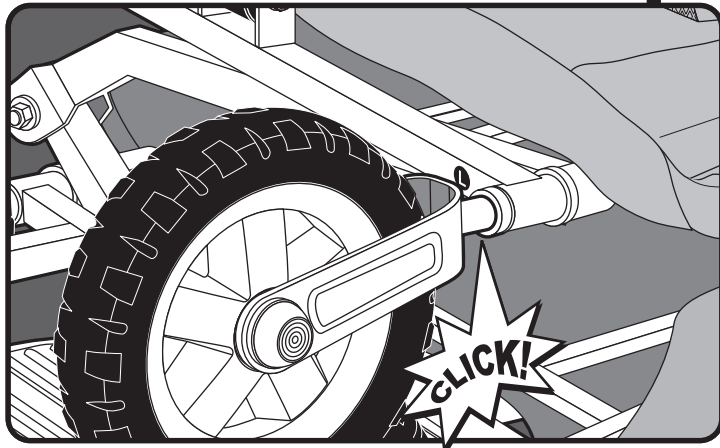
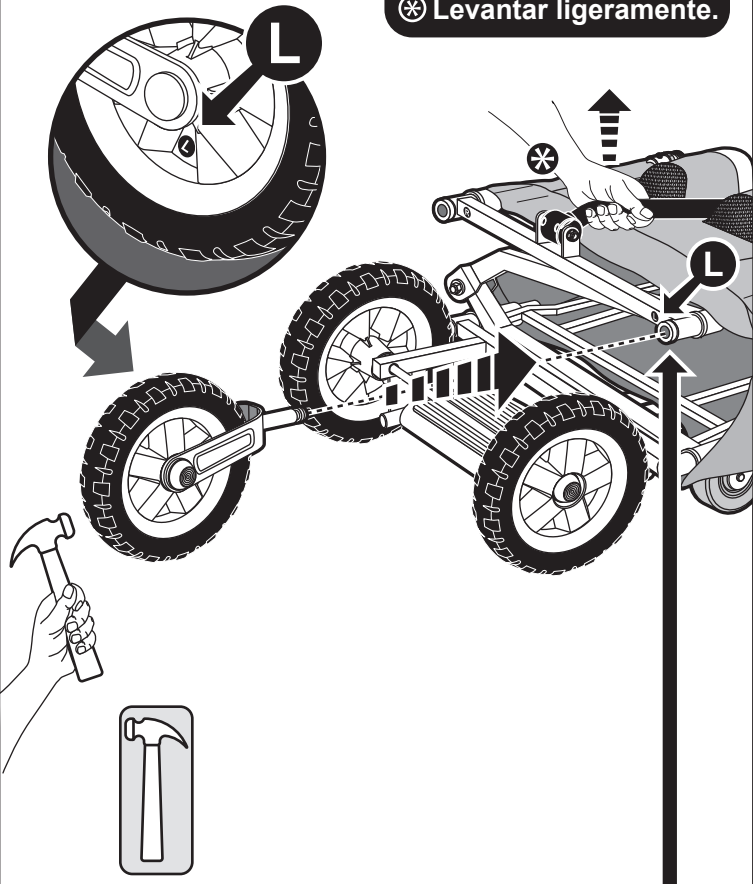

9

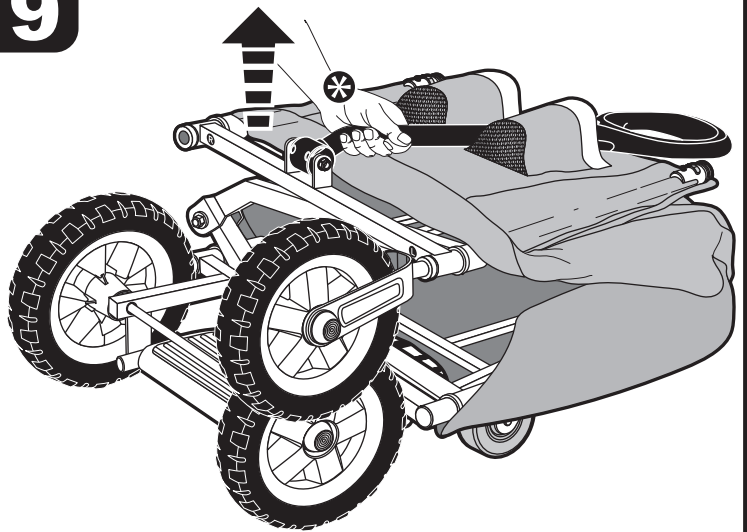

- ⊗ Lift slightly.
- ⊗ Lever légèrement.
- ⊗ Levantar ligeramente.

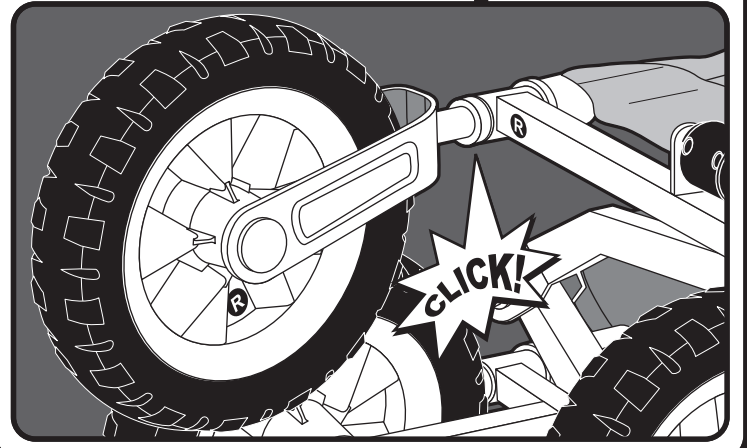
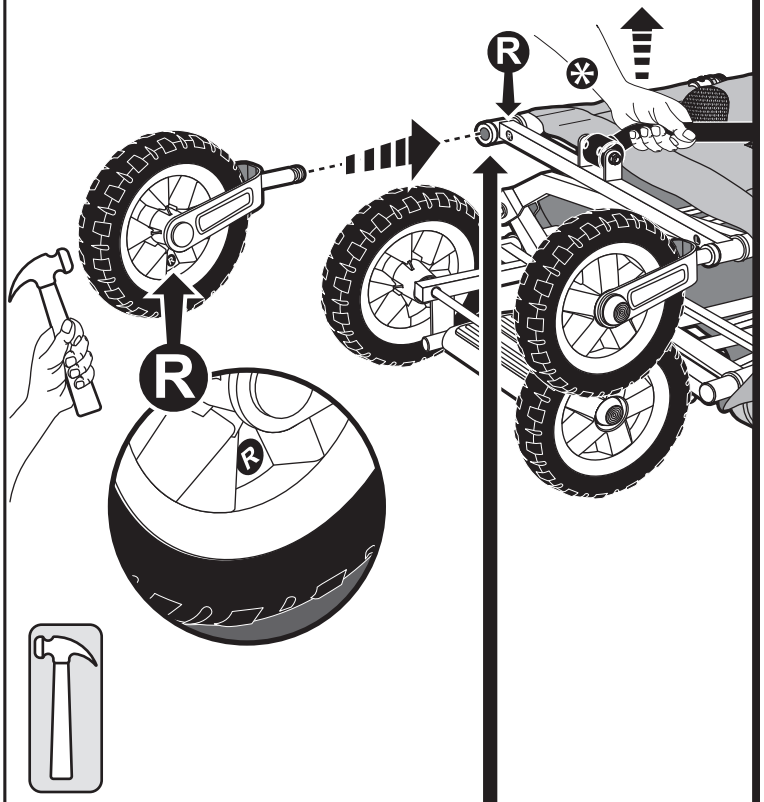

10

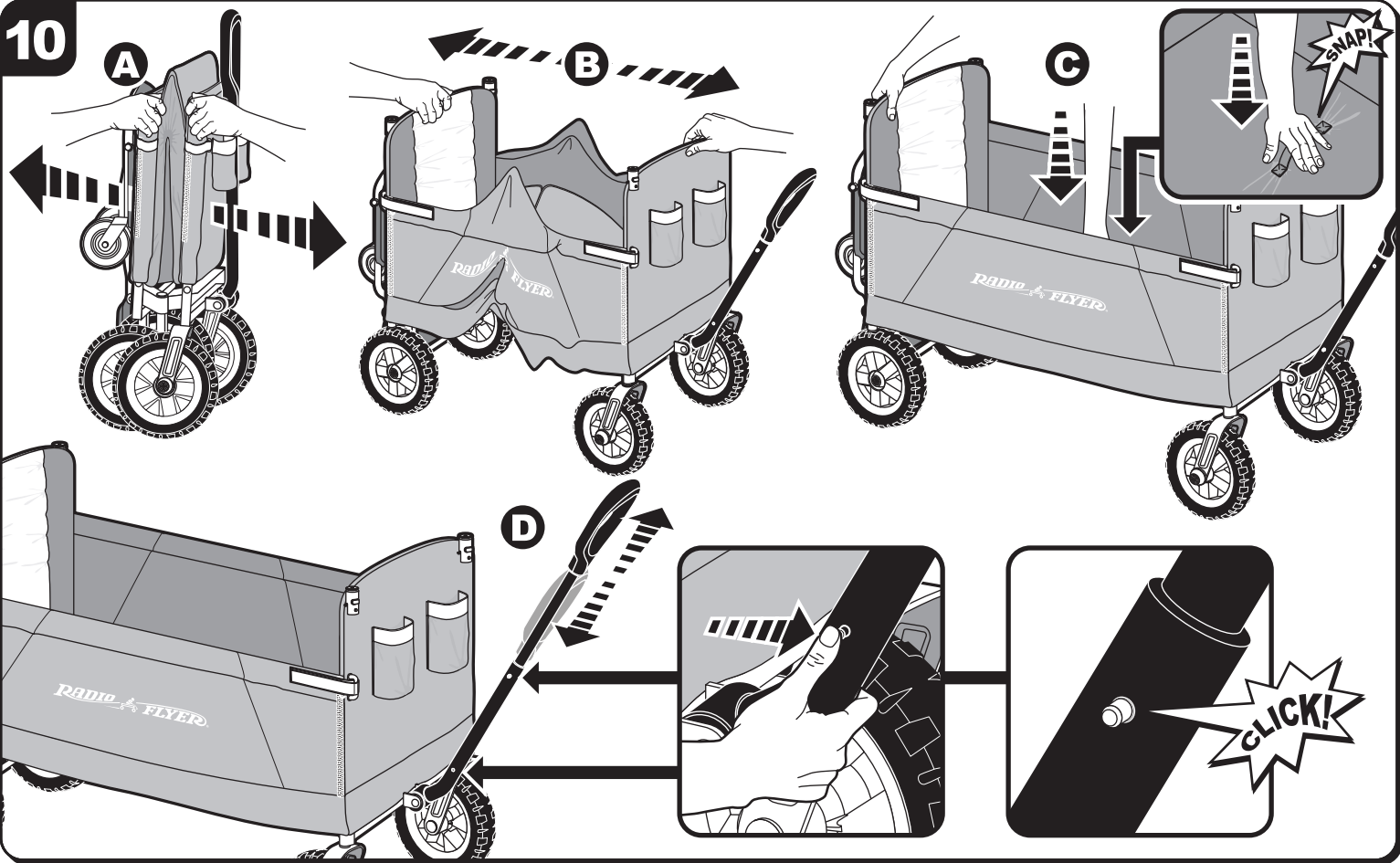

11

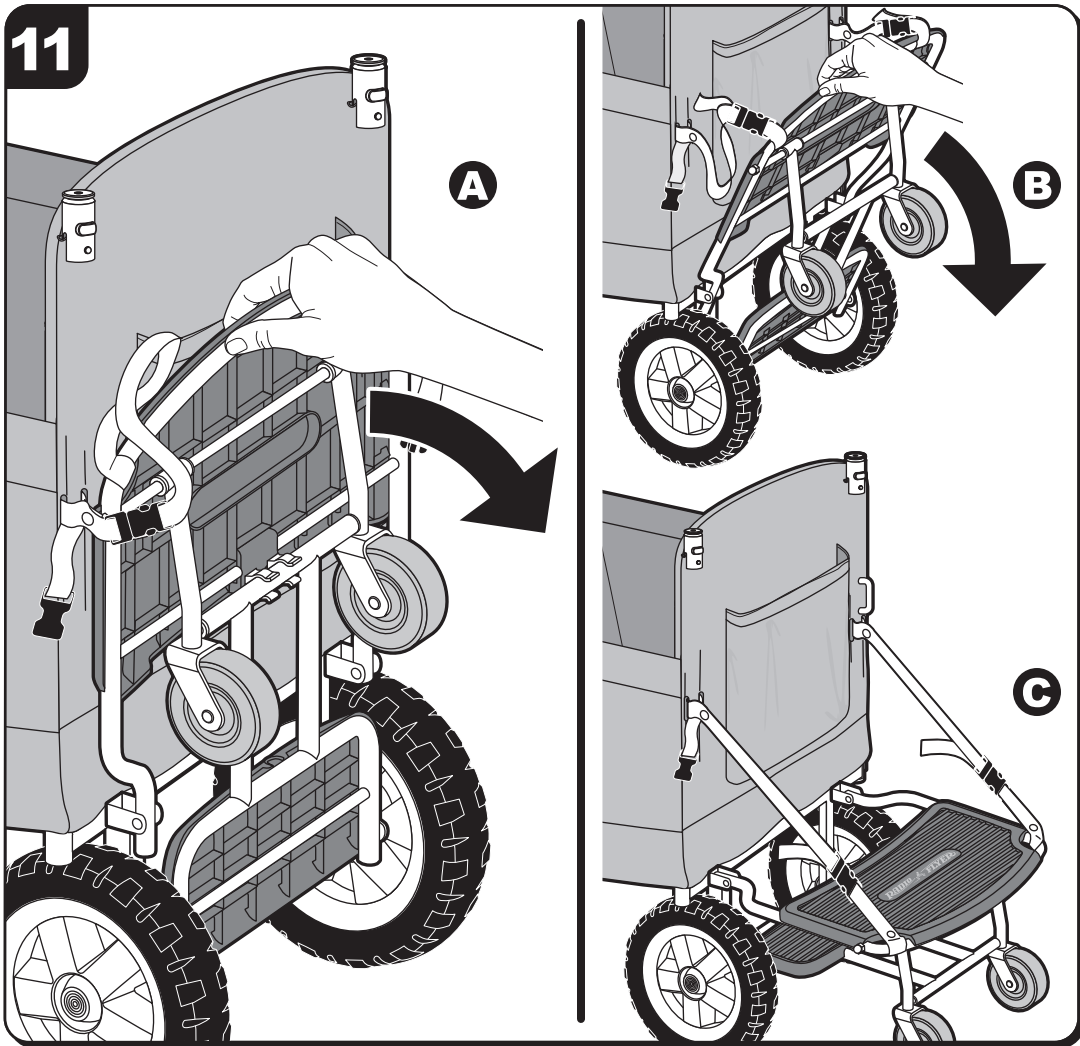

12

- For bag chair storage:
- Pour le stockage de chaise:
- Para el almacenamiento de la silla:

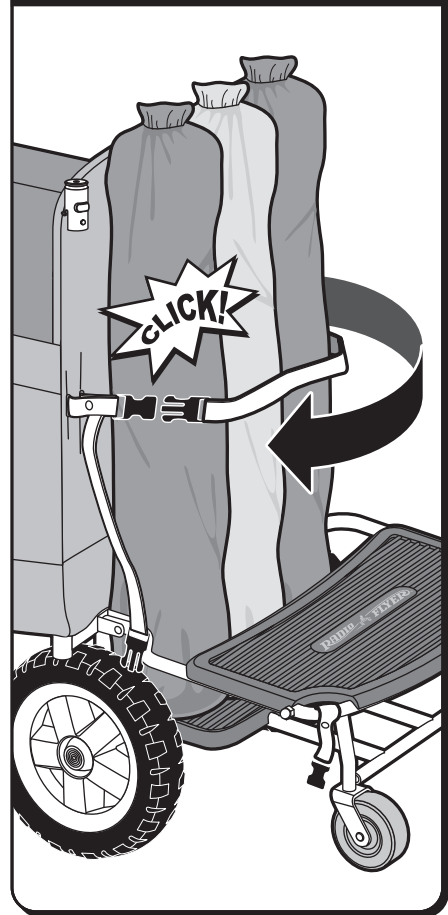

13

- For cooler storage:
- Pour un stockage plus frais:
- Para un almacenamiento más fresco:

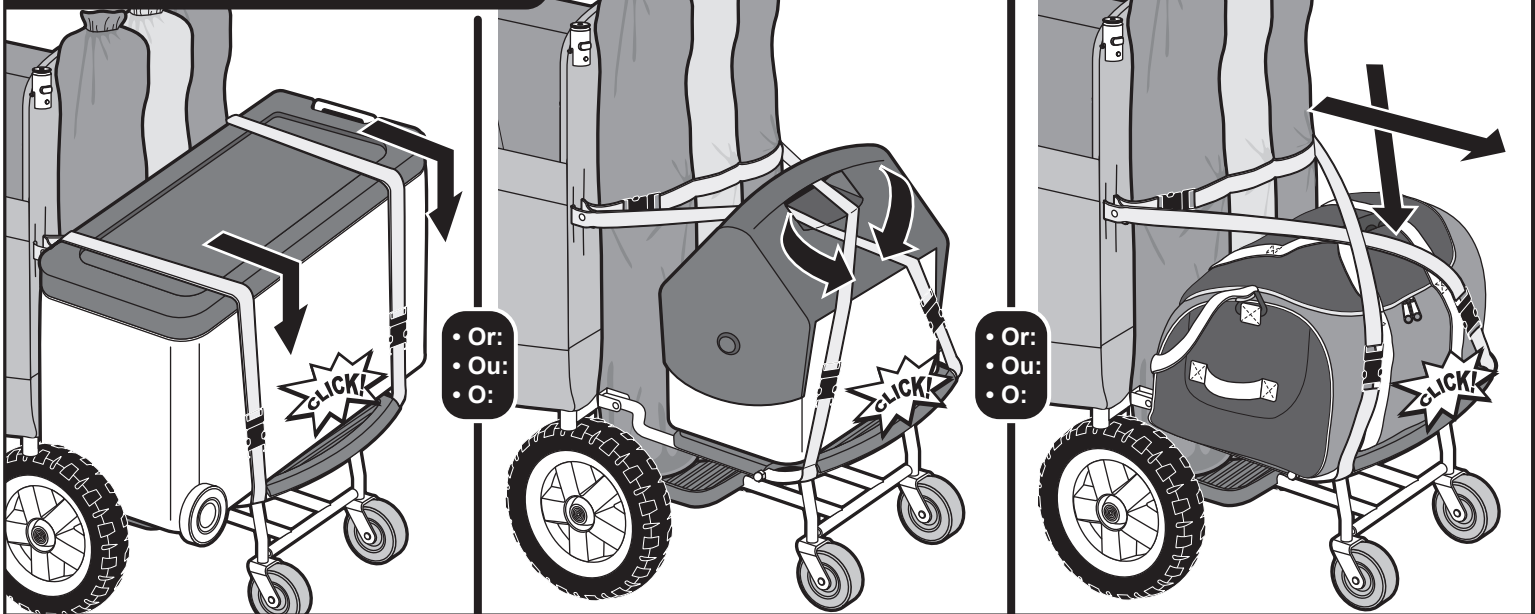

• Or:
• Ou:
• O:

• Or:
• Ou:
• O:

- ⚠ WARNING:** Make sure items are secure before use. Use caution if using your own bungee cords or elastic straps due to snap back hazard.
- ⚠ AVERTISSEMENT:** Assurez-vous que les articles sont sécurisés avant utilisation. Faites preuve de prudence si vous utilisez vos propres cordons élastiques ou sangles élastiques en raison du risque de happement.
- ⚠ ADVERTENCIA:** Asegúrese de que los artículos estén seguros antes de su uso. Tenga cuidado si usa sus propios cordones elásticos o correas elásticas debido al peligro de retroceso.

14

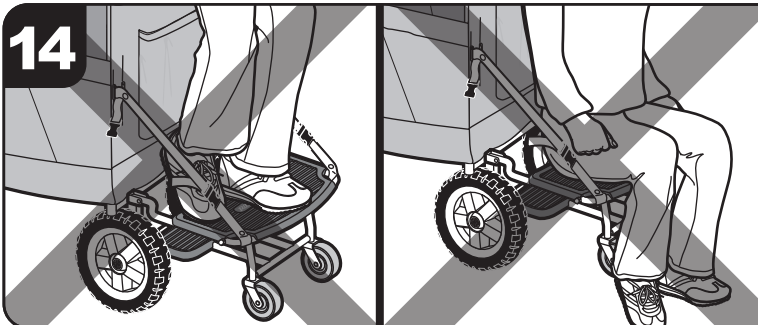

- ⚠ CAUTION:** FOR CARGO ONLY. Do not sit or stand on trailer.
- ⚠ ATTENTION:** POUR CARGO SEULEMENT. Ne pas s'asseoir ou se tenir debout.
- ⚠ PRECAUCIÓN:** PARA CARGA SOLAMENTE. No te sientes ni te pases.

15

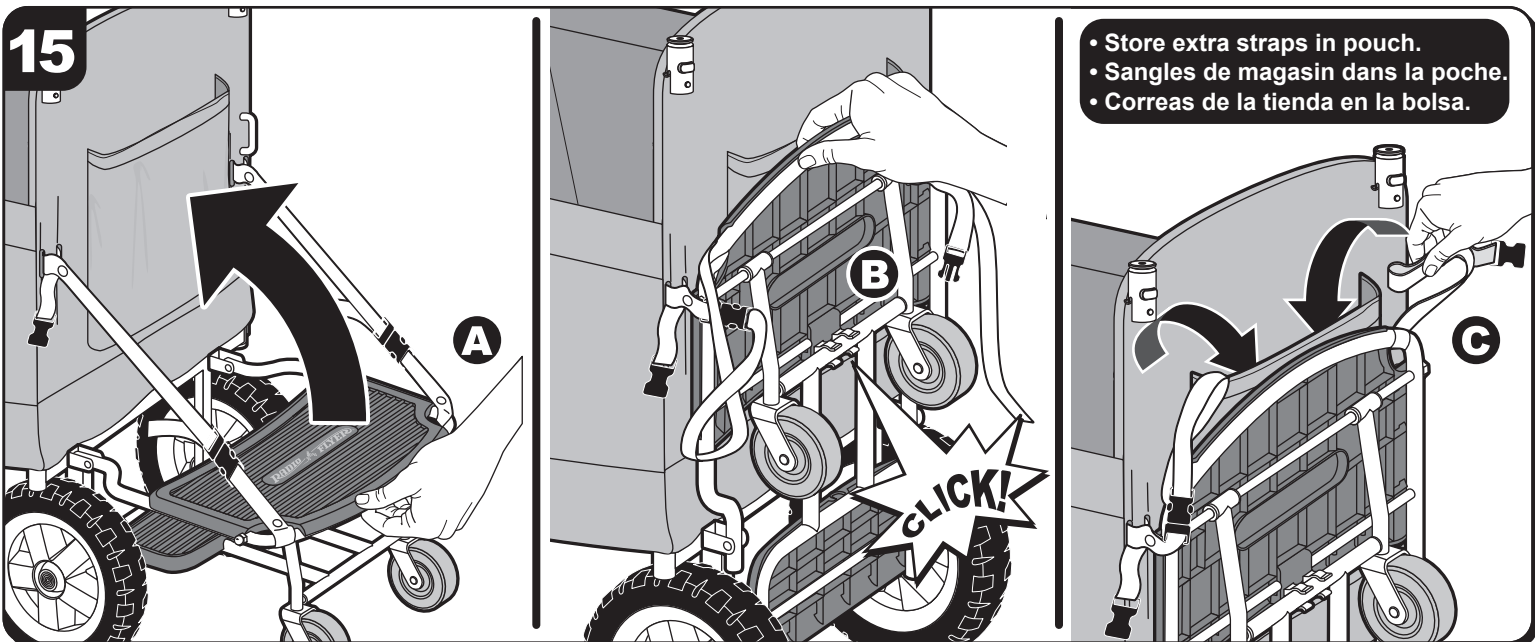

- Store extra straps in pouch.
- Sangles de magasin dans la poche.
- Correas de la tienda en la bolsa.

16

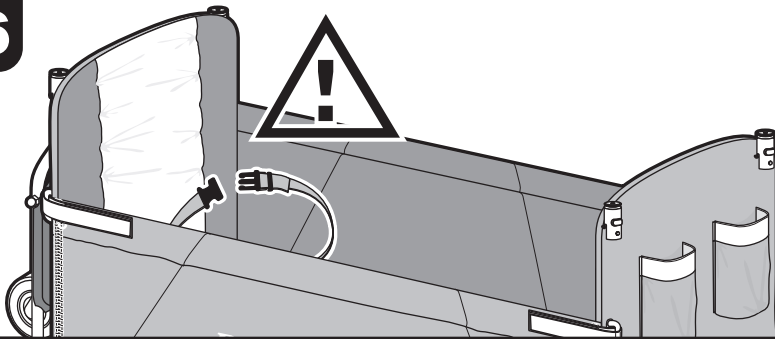

CAUTION: Use harness to secure child to wagon seat.



ATTENTION: Utiliser harnais pur obtenir l'enfant au siege de chariot.



PRECAUCIÓN: Use arros para asegurar a niño asiento del carro.

17

- Convert to bench.
- Convertir en banc.
- Convertir a la banca.

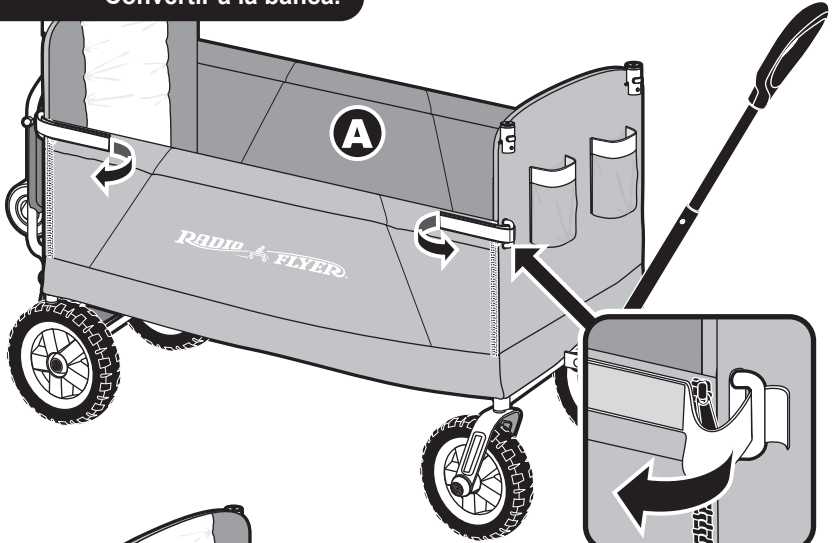

18

- Convert to wagon.
- Convertir en wagon.
- Convertir al vagón.

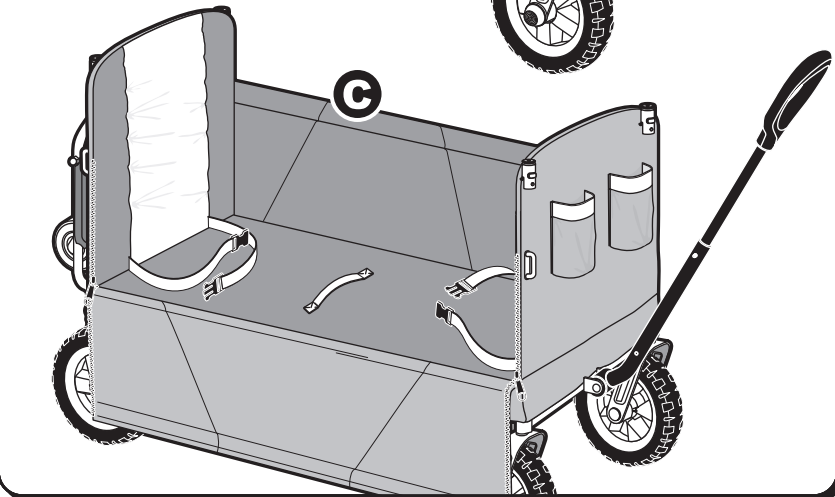
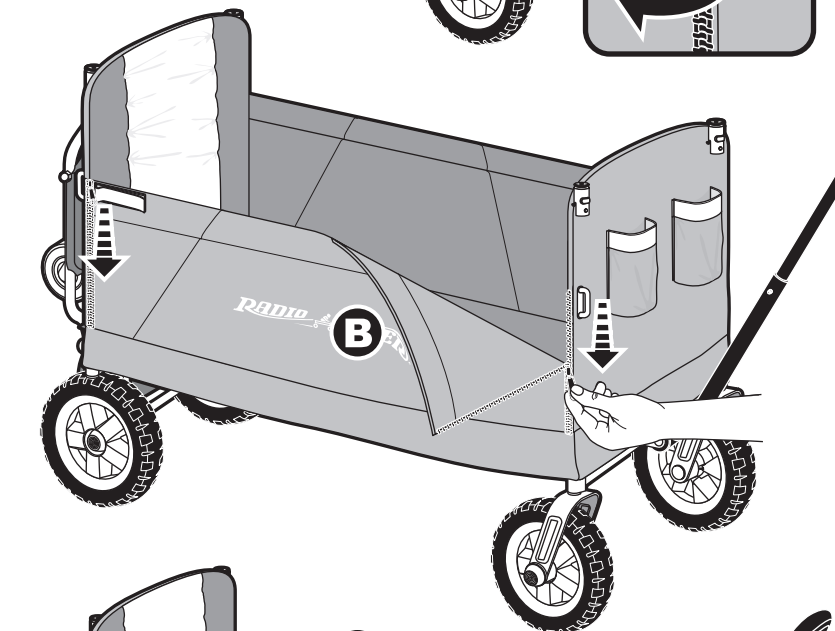
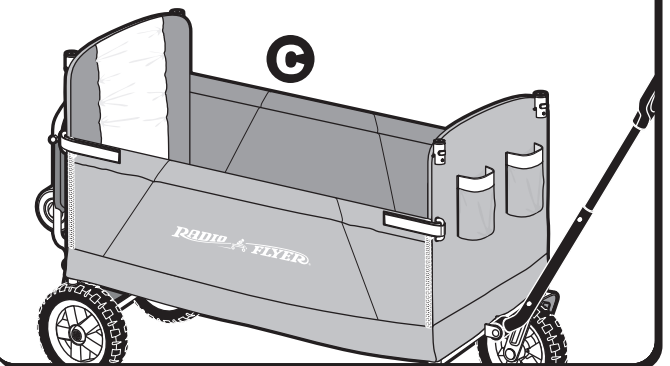
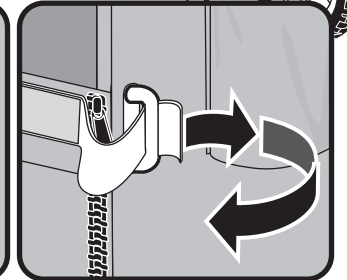
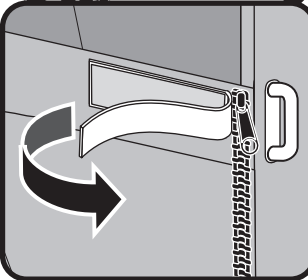
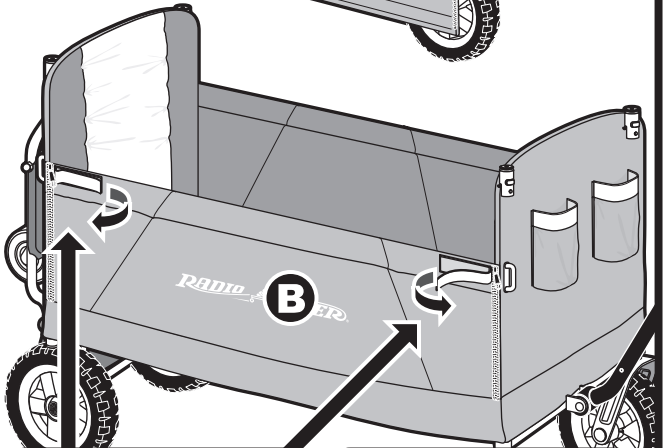
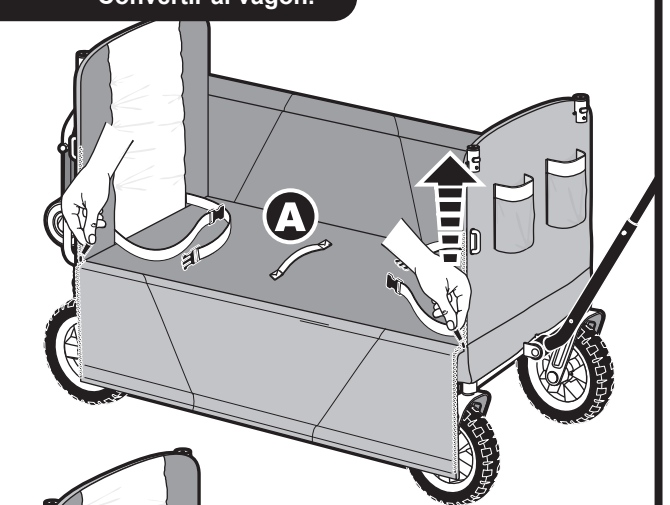

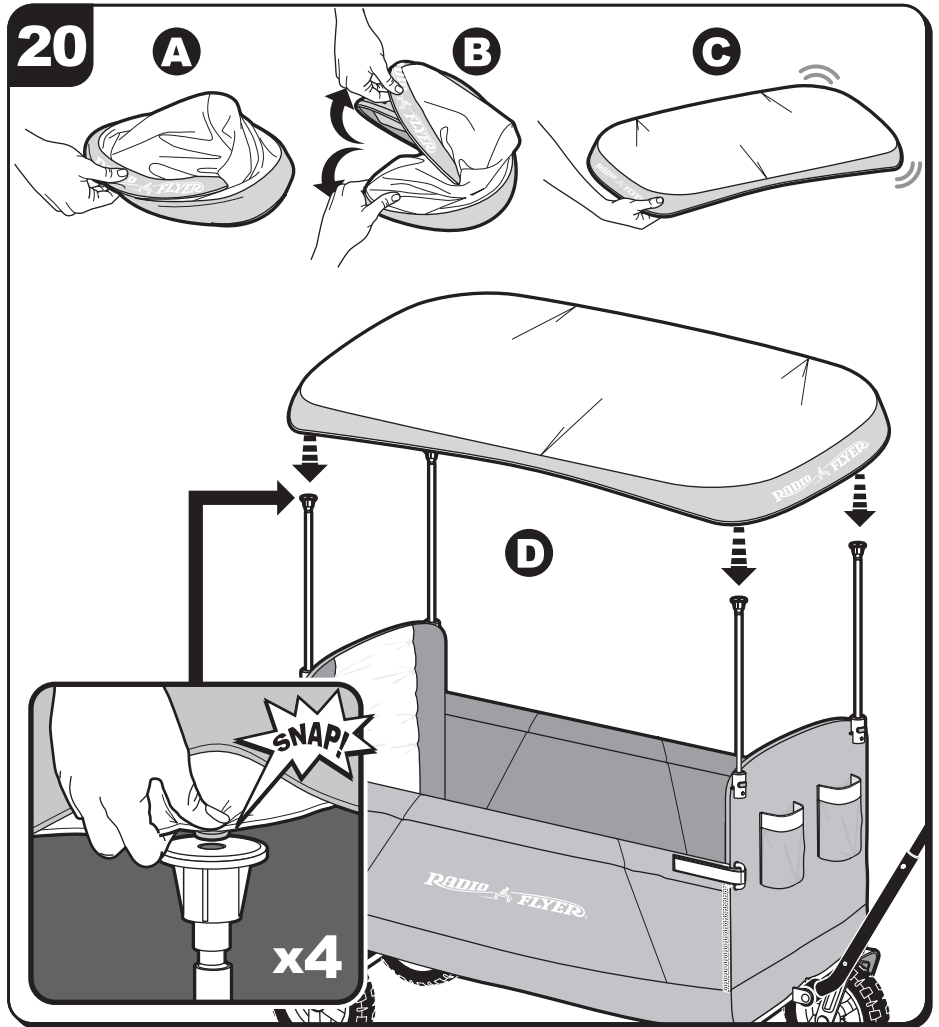
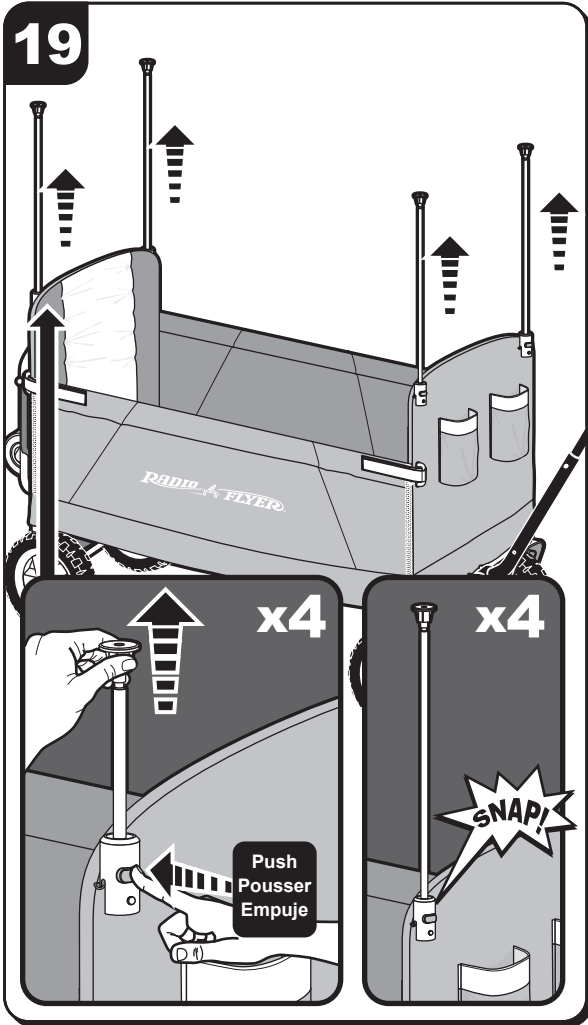

21

- Folding the canopy:
- Pliage de l'auvent pour rangement:
- Pliegue la capota para su almacenamiento:

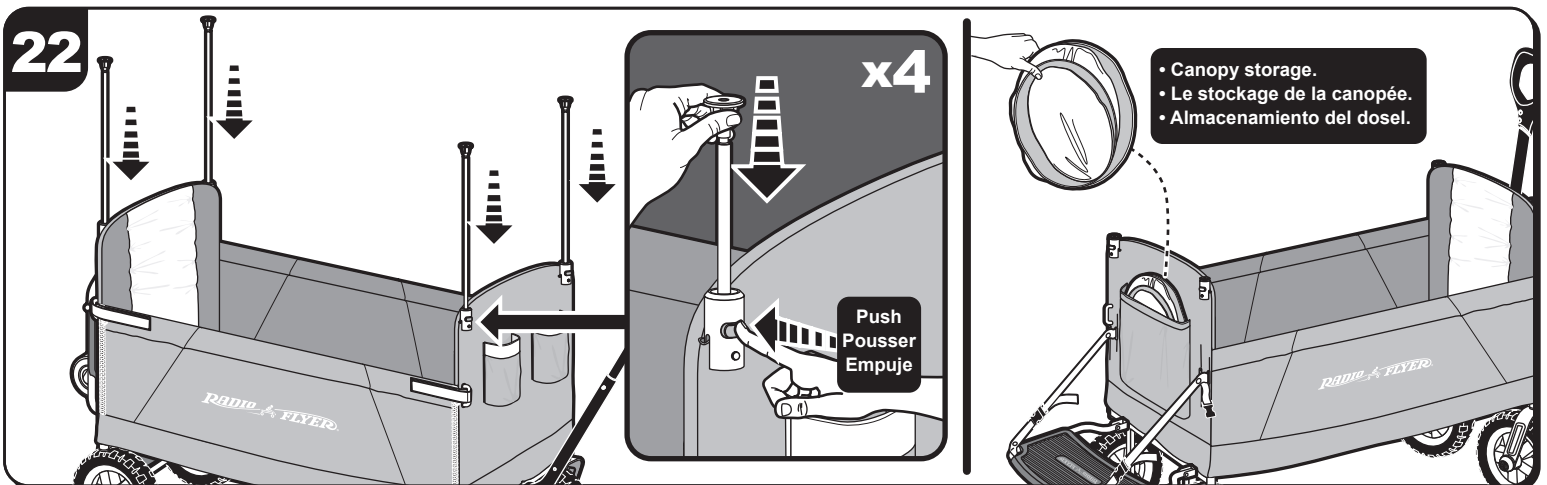
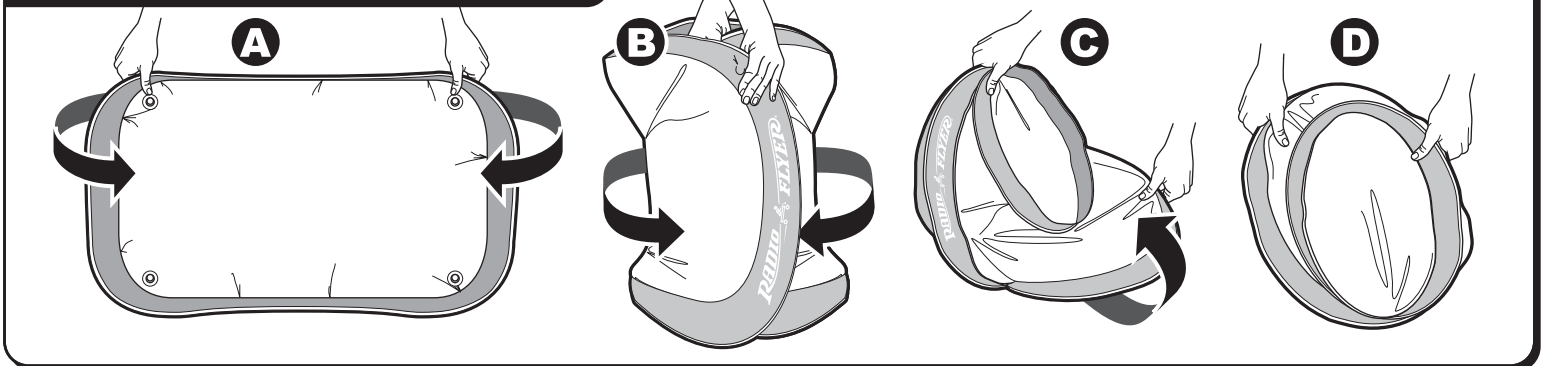

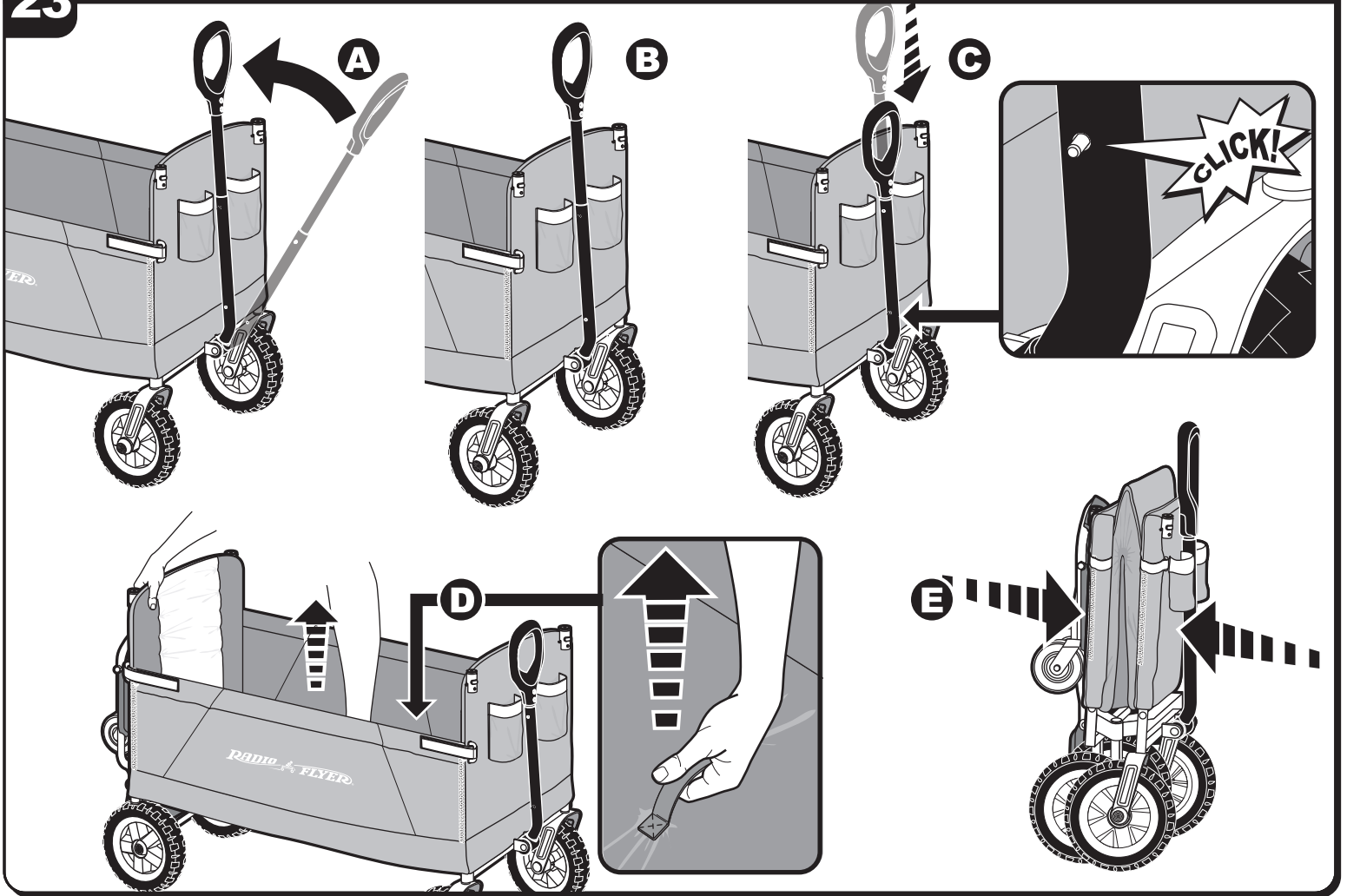

⚠️ WARNING:
TO AVOID SERIOUS INJURY:

- Continuous adult supervision is required.
- Never use near motor vehicles, streets, roads, alleys, swimming pool areas, hills, steps, sloped driveways, inclines and public highways.
- No more than 2 riders at a time.
- Passengers should remain seated while riding the wagon.
- To prevent falls or injuries, children must remain seated with their arms and legs inside the wagon while riding.
- Never ride the wagon outside at night.
- Never use in wet weather.
- Maximum weight this wagon is designed to carry is 150.0 lbs (68.0 kg) inside the wagon, 50.0 lbs (22.7 kg) on the upper caddy tray and 30 lbs (13.6kg) on the lower tray. Excessive weight can cause a hazardous or unstable condition.
- Do not sit, stand or step on rear caddy.
- Always ensure caddy straps are safely stored away when not in use.
- Periodically check hardware and tighten if necessary. Replace worn or broken parts immediately.
- Unfold and lock wagon in riding position before use.
- Only adults should fold and unfold the wagon

⚠️ AVERTISSEMENT:
POUR ÉVITER TOUTE BLESSURE GRAVE:

- La surveillance continue par un adulte est exigée.
- Ne jamais utilisez près des véhicules à moteur, des rues, des chaussées, des allées, au environs des piscine, des collines, des marches, est des descente en pente des allées, des pentes et des autoroutes publiques.
- Pas plus de 2 passagers en même temps.
- Les passagers doivent restés assis quand ils conduisent le chariot.
- Pour éviter toute chute ou blessure, les enfants ne doivent pas laisser dépasser leurs bras ou leurs jambes et rester assis dans le chariot lorsqu'il est en mouvement.
- Le chariot ne doit jamais être utilisé de nuit.
- Ne joue jamais avec ton chariot par temps de pluie.
- Le poids maximum que peut supporter le chariot est de 68.0 kg (150.0 livres) à l'intérieur du wagon, de 22.7 kg (50.0 livres) sur le plateau du chariot supérieur et de 13.6 kg (30.0 livres) sur le plateau inférieur. Un poids excessif peut entraîner une situation dangereuse ou instable.
- Ne vous asseyez pas, ne vous tenez pas debout ou ne marchez pas sur le chariot arrière.
- Assurez-vous toujours que les sangles du chariot sont bien rangées lorsqu'elles ne sont pas utilisées.
- Vérifiez souvent les boulons et écrous et resserrez les si nécessaire. Remplacez les pièces usées ou endommagées immédiatement.
- Déplier et verrouiller wagon en position de conduite avant de l'utiliser.
- Seuls les adultes devraient plier et déplier le wagon.

⚠️ ADVERTENCIA:
PARA EVITAR LESIONES GRAVES:

- La supervisión adulta continua requerida.
- Nunca uso cerca de automóviles, calles, carreteras, callejones, áreas de piscinas, colinas, pasos, calzadas inclinadas, inclinaciones y carreteras públicas.
- No se deben montar más de dos personas a la vez.
- Los pasajeros deben mantenerse sentados en todo momento mientras se está en el carrito.
- Para evitar caídas o lesiones, cuando los niños utilicen el carro deben permanecer sentados, sin sacar los brazos ni las piernas.
- Nunca use el carrito en exteriores durante la noche.
- Nunca usar el carrito si está lloviendo.
- El peso máximo que puede soportar es de 68.0 kg (150.0 libras) dentro del vagón, 22.7 kg (50.0 libras) en la bandeja superior del carrito y 13.6 kg (30.0 libras) en la bandeja inferior. El peso excesivo puede causar una condición peligrosa o inestable.
- No se sienten, se pare o pise el carrito trasero.
- Siempre asegúrese de que las tiras de caddy estén almacenadas de manera segura cuando no estén en uso.
- Compruebe el hardware y apriete periódicamente en caso de necesidad. Reemplace inmediatamente las piezas dañadas o gastadas.
- Despliegue y bloquee vagón en posición de conducción antes de su uso.
- Sólo los adultos deben plegar y desplegar la carreta.