

# RADIO FLYER

## GIRL'S CLASSIC LIGHTS & SOUNDS TRIKE

**model/modèle/modelo #46G**

Patents pending / Brevets en attente / Patente pendiente

**For ages 2 to 5 years**

**Pour enfants de 2 à 5 ans**

**Para los niños 2 a 5 años**

Thank you for your purchase. If you have any questions or comments, please visit the customer service section of our website:

Merci d'avoir acheté notre produit. Si vous avez des questions ou commentaires, veuillez référer notre site web dans la section de service à la clientèle.

Gracias por su compra. Si tiene preguntas o comentarios por favor visite la sección, servicio al cliente de nuestro website:

**www.radioflyer.com**

Or phone / ou composez le / o llame al 1-800-621-7613

Available weekdays 8:00 a.m. to 5:00 p.m. CST.

Please keep this sheet for future reference.

Disponible sur semaine de 8:00 heures 17:00 heures.

Veuillez garder cette feuille comme référence.

Lunes a viernes de 8:00 a.m. a 5:00 p.m. CST.

Por favor retenga esta copia para futura referencia.

Radio Flyer Inc. / 6515 West Grand Ave. / Chicago, IL 60707

phone: 773-637-7100 fax: 773-637-8874

**The Original Little Red Wagon™ - Since 1917**

**1**

**Tools Required:**  
**Outils nécessaires:**  
**Herramientas necesarias:**



Or:  
Ou:  
O:

**2**

46G.1080099 (x1)

46G.1080199 (x1)

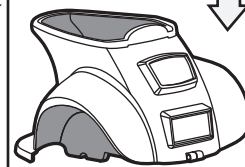
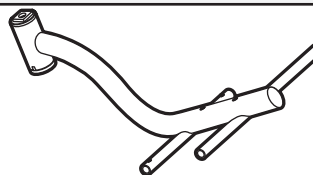

46.1070299 (x1)

46.1081499 (x1)

46G.1080399 (x1)

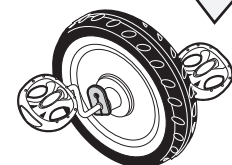

46G.1080499 (x1)

46G.1080999 (x1)

46G.1080599 (x1)

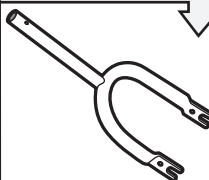

46G.1081099 (x2)

46G.1080699 (x1)

46G.1080799 (x1)

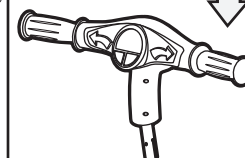
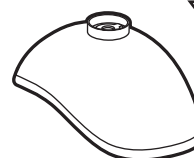

46.1071299 (x1)



**3**

80.0451099 (x2)

46.1071499 (x5)

46.1070399 (x6)



1 Extra  
1 Supplémentaire  
1 Adicional

46G.1080899 (x2)

46.1071699 (x2)

46.1071799 (x2)

46.1071399 (x2)

46.1071899 (x1)

46.1081399 (x3)

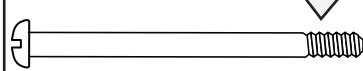
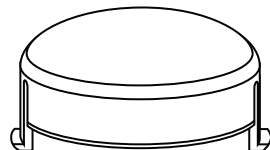

M4 x 44

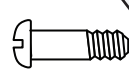

M4 x 12



M4 x 10

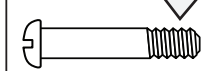

M4 x 21



M3 x 10



- If you find extra hardware items, please dispose of them and keep them away from small children.
- Si vous avez de éléments en surplus, rangez-les dans un endroit sûr, à l'abri des bambins.
- Deshacerse de la ferreteria que le sobre, manteniéndolo fuera del alcance de los niños.

**4**

**CAUTION:**

**ADULT ASSEMBLY REQUIRED.**

This package contains small parts which, before assembly, present a choking hazard to children under the age of three. Care should be taken during unpacking and assembly to insure that all small parts and plastic bags are accounted for and kept out of the reach of children.

Please keep instructions for future reference.

**ATTENTION:**

**ASSEMBLAGE REQUIS PAR ADULTE.**

Cet emballage contient de petites pièces qui, avant l'assemblage, présentent un danger potentiel de suffocation avec les enfants âgés de moins de trois ans. Prendre les précautions nécessaires au cours du déballage et de l'assemblage afin de garantir que toutes les pièces et plastique sacs ont été incluses et tenues à l'écart des enfants.

Veuillez garder les instructions comme référence aux besoins.

**PRECAUCIÓN:**

**MONTAJE REQUERIDO POR ADULTOS.**

Este paquete contiene pequeñas piezas que, antes del montaje, presentan un peligro potencial de asfixia para niños de menos de tres años de edad. Se debe tener todas las piezas pequeñas y plástico bolsas y ponerlas fuera del alcance de los niños.

Mantenga por favor las instrucciones para la referencia futura.

5

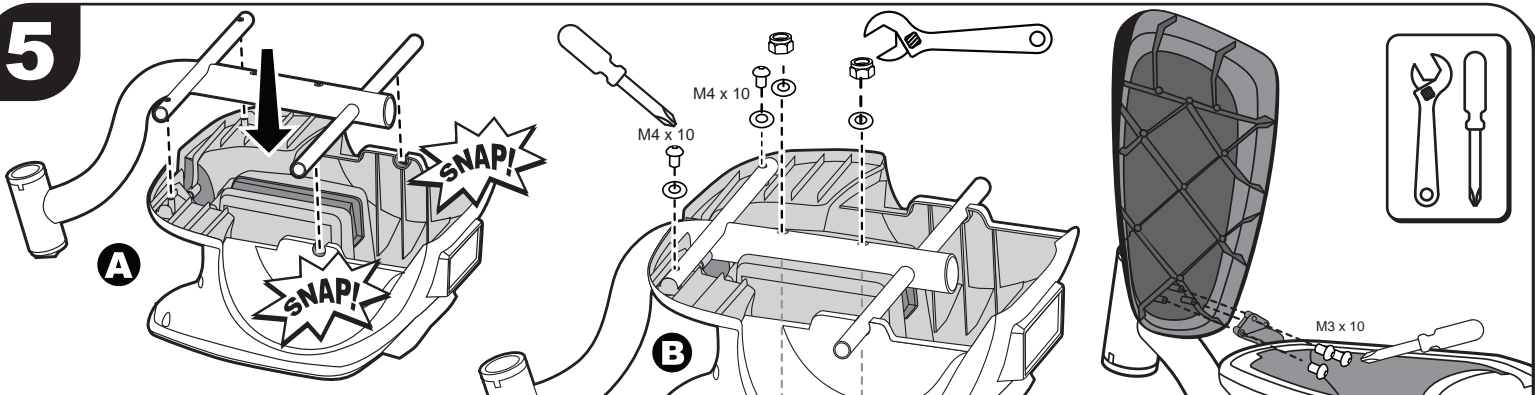

46.1071399 (x2) 46.1070399 (x2)



46.1071699 (x2) 46.1070399 (x2) 46.1071499 (x2) 46.1081399 (x3)



6

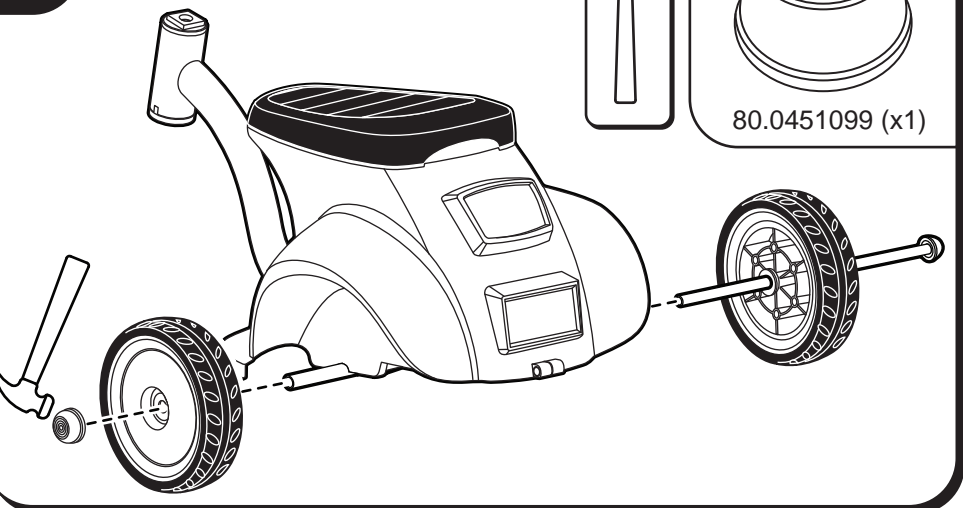

7

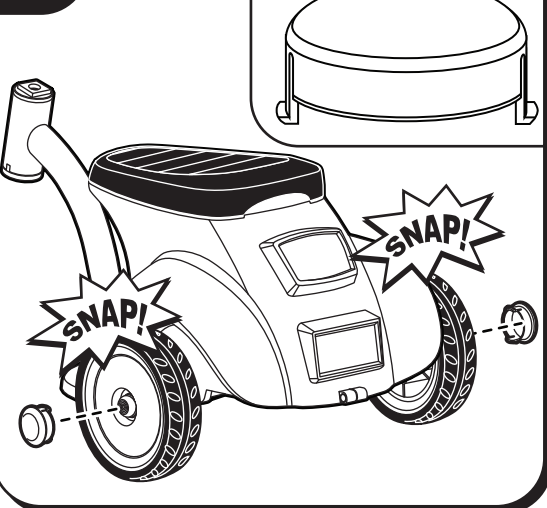

8

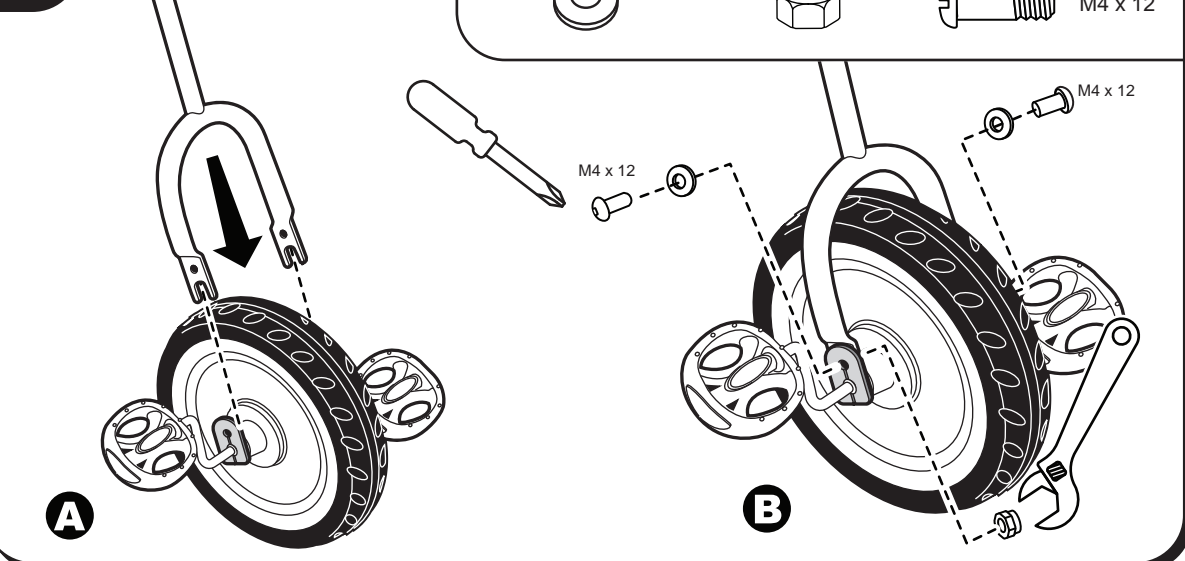

9

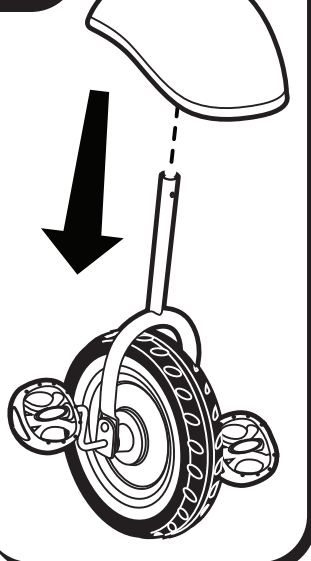

10

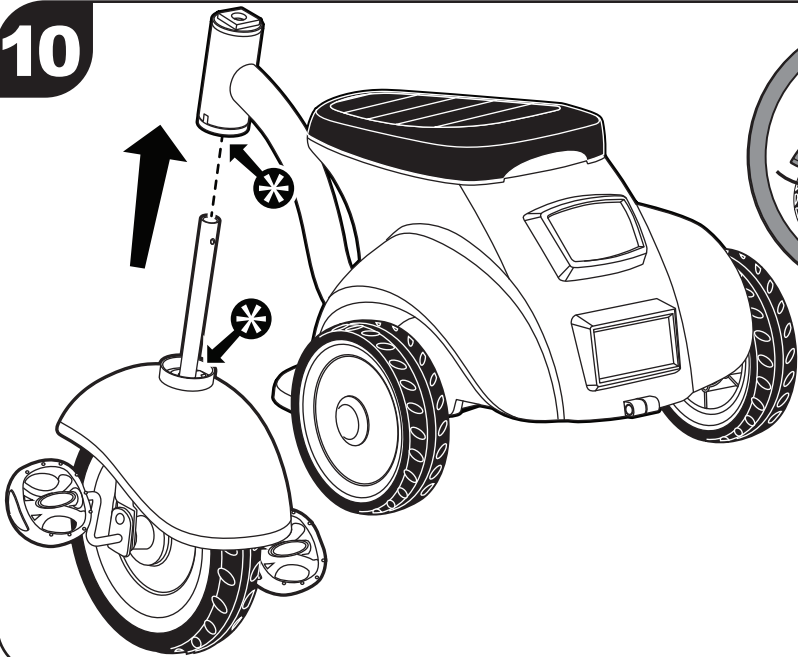

FRONT  
AVANT  
FRENTE

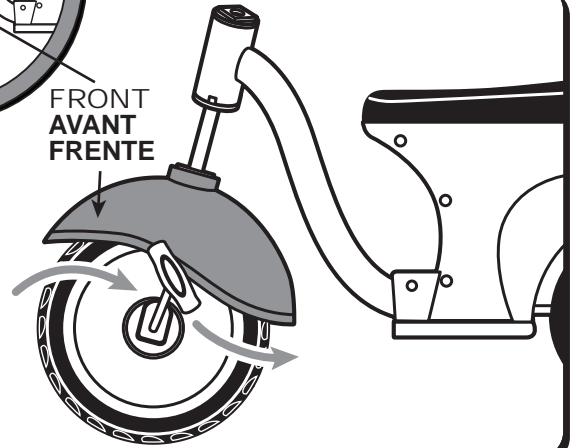

11

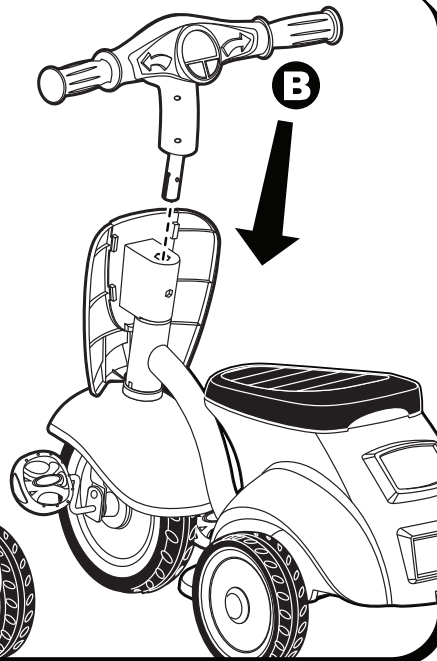
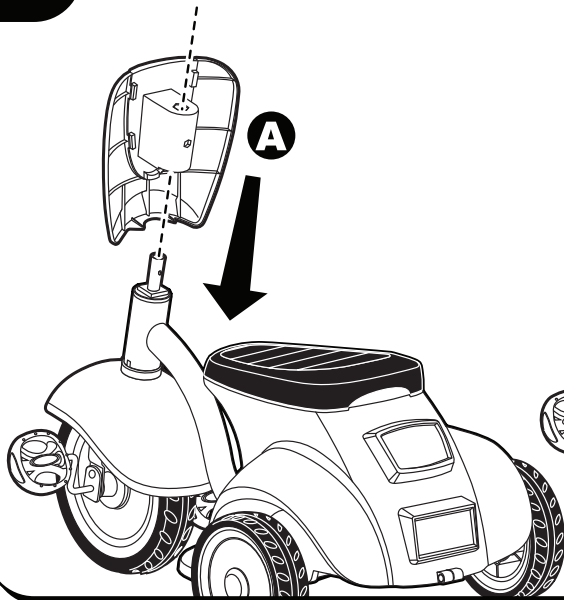

12

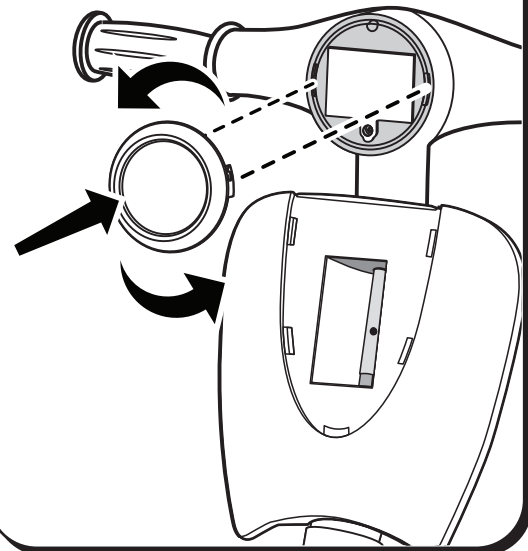

13

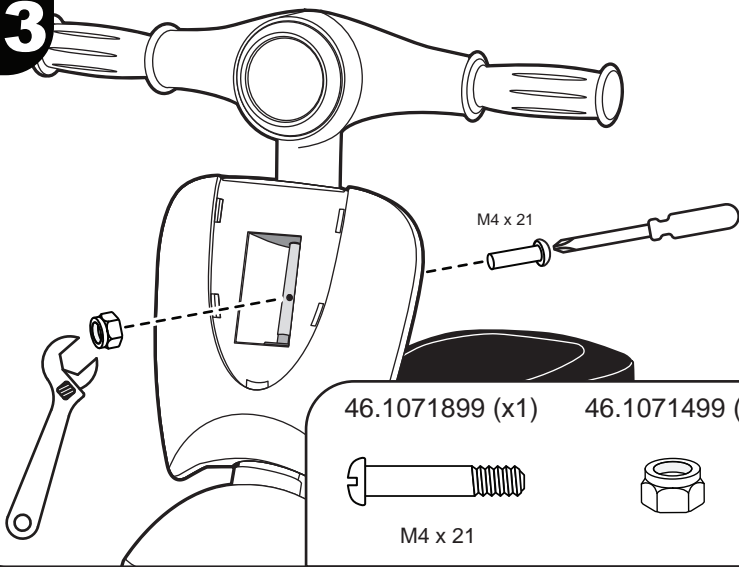

14

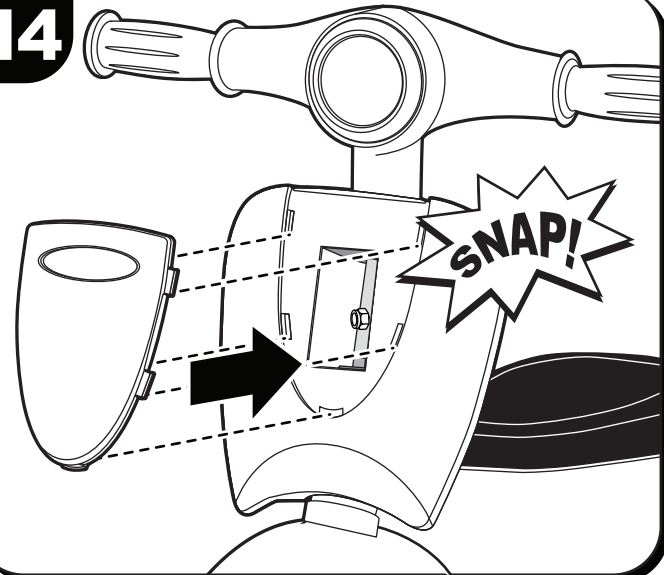

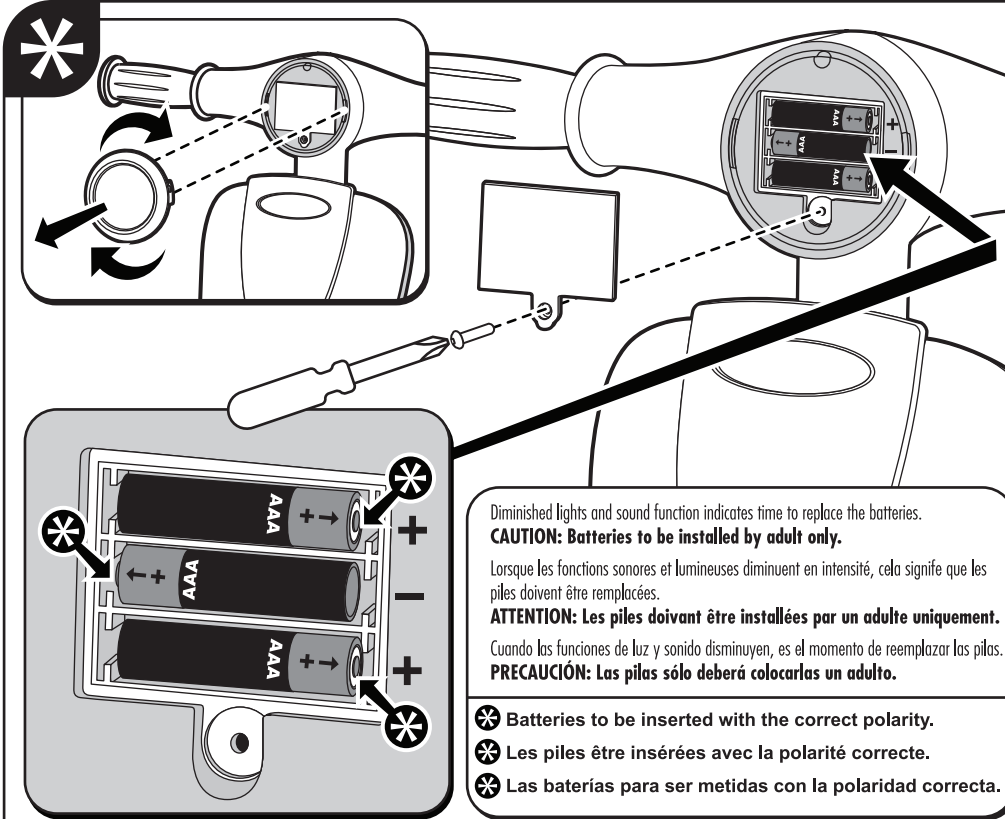

**Caution : To Avoid Battery Leakage**

DO NOT mix old and new batteries.  
 DO NOT mix alkaline, standard (carbon-zinc), or rechargeable (nickel-cadmium) batteries.  
 DO NOT incinerate used batteries / DO NOT dispose of batteries in fire  
 DO NOT use rechargeable batteries  
 DO NOT recharge non-rechargeable batteries  
 DO NOT short-circuit the supply terminals  
 Only batteries of the same or equivalent type as recommended are to be used.  
 Exhausted batteries should be removed from the toy.  
 For the best performance we recommend replacing the batteries that come with the car with three new alkaline "AAA" (LR3) batteries.

**Attention : pour éviter les fuites**

NE PAS mélanger des piles neuves avec des piles déjà utilisées.  
 NE PAS mélanger des piles alcalines avec des piles standard (carbone-zinc) ou des piles rechargeables (nickel-cadmium).  
 NE PAS incinérer les piles usagées / NE PAS brûler les piles  
 NE PAS utiliser des piles rechargeables  
 NE PAS recharger des piles non-rechargeables  
 NE PAS court-circuiter les points de livraison  
 Sólo baterías del tipo mismo o equivalente como recomendado deberán ser utilizadas.  
 Las baterías agotadas deberán ser quitadas del juguete.  
 Pour une meilleure performance nous recommandons de remplacer les batteries qui sont venues ia voiture avec trois nouvelles piles alcaline "AAA" (LR3).

**Precaución: Para evitar que las pilas se descompongan**

NO mezcle las pilas viejas con las nuevas.  
 NO mezcle pilas alcalinas, estándar (zinc carbono) o recargables (níquel cadmio).  
 NO incinere las pilas usadas / NO exponga las pilas usadas al fuego  
 NO utilice pilas recargables  
 NO recargue pilas no recargables  
 NO haga corto circuito en las terminales  
 Seulement les piles de type pareil ou équivalent comme recommandé va être utilisé.  
 Les piles épuisées devraient être enlevées du jouet.  
 Para el mayor desempeño, nosotros recomendamos reemplazando las baterías que vinieron con el coche con tres nuevas baterías alcalinas "AAA" (LR3).

Diminished lights and sound function indicates time to replace the batteries.  
**CAUTION: Batteries to be installed by adult only.**  
 Lorsque les fonctions sonores et lumineuses diminuent en intensité, cela signifie que les piles doivent être remplacées.  
**ATTENTION: Les piles doivent être installées par un adulte uniquement.**  
 Cuando las funciones de luz y sonido disminuyen, es el momento de reemplazar las pilas.  
**PRECAUCIÓN: Las pilas sólo deberá colocarlas un adulto.**

- ✳ Batteries to be inserted with the correct polarity.
- ✳ Les piles être insérées avec la polarité correcte.
- ✳ Las baterías para ser metidas con la polaridad correcta.

Requires 3 "AAA" (called LR3 in some countries) batteries. Install new batteries as shown in the polarity diagram (+/-) inside battery compartment.  
 Fonctionne avec 3 piles "AAA" (LR3). Mettre de nouvelles piles comme indiqué sur le diagramme de polarité (+/-) à l'intérieur du compartiment.  
 Funciona con pilas 3 AAA-LR3. Coloque las pilas nuevas siguiendo el diagrama de polaridad (+/-) que se muestra dentro del compartimiento para las baterías.

**! FCC Statement (U.S. Only)**  
 This equipment has been tested and found to comply with the Limits for a Class B digital device, pursuant to part 15 of the FCC Rules. These limits are designed to provide reasonable protection against harmful interference in a residential installation. This equipment generates, uses and can radiate radio frequency energy, and, if not installed and used in accordance with the instructions, may cause harmful interference to radio communications. However, there is no guarantee that interference will not occur in a particular installation. If this equipment does cause harmful interference to radio or television reception, which can be determined by turning the equipment off and on, the user is encouraged to try to correct the interference by one or more of the following measures:

- Reorient or relocate the receiving antenna.
  - Increase the separation between the equipment and the receiver.
  - Consult the dealer or an experienced radio/TV technician for help.
- CAUTION: Changes or modifications not expressly approved by the party responsible for compliance could void the user's authority to operate the equipment.

**! WARNING:**

**TO AVOID SERIOUS INJURY:**

- Continuous adult supervision is required.
- Never use near motor vehicles, streets, roadways, alleys, swimming pool areas, hills, steps, sloped driveways, inclines and public highways.
- Only one rider at a time.
- Always wear shoes when using the toy.
- Periodically check hardware and tighten if necessary. Replace worn or broken parts immediately.
- Never ride the toy in wet weather.
- Never ride the toy outside at night.
- Maximum weight **50 lbs. (22.7 kg)**
- This toy is not suitable for children over **60 months** due to insufficient strength and size.
- Do not allow children to stand on the product at any time.
- We recommend riders always wear a properly fitted helmet that complies with U.S. Consumer Product Safety Commission (CPSC) Standard 16 CFR 1203;
- **Maximum permissible load for storage bin is 5 lbs. Excessive weight may cause a hazardous or unstable condition.**

**! AVERTISSEMENT**

**POUR ÉVITER TOUTE BLESSURE GRAVE:**

- La supervision continu d'un adulte est exigée.
- Ne jamais utilisez près des véhicules à moteur, des rues, des chaussées, des allées, au environs des piscine, des collines, des marches, est des descente en pente des allées, des pentes et des autoroutes publiques.
- Seulement un cavalier à la fois.
- Ne conduisez jamais sans chaussures.
- Vérifiez souvent les boulons et écrous et resserrez les si nécessaire. Remplacez le pièces usées out endommagées immédiatement.
- Ne conduise pas cette jouet par temps de pluie.
- Ne conduise pas cette jouet la nuit.
- Charge maximale **50 livres (22.7 kg)**.
- En raison de sa taille et de sa solidité, ce jouet ne convient pas aux enfants de plus de **60 mois**.
- Toujours interdire aux enfants de se matter debout dans la voiture.
- Nous recommandons aux utilisateurs de porter systématiquement un casque bien attaché, conformément à la norme 16 CFR 1203 de l'U.S. Consumer Product Safety Commission (CPSC);
- **Charge maximale pour le bac de rangement: 5 livres (2,25 kg). Le dépassement de cette limite de poids pour rait entraîner des conditions instables ou dangereuses.**

**! ADVERTENCIA**

**PARA EVITAR LESIONES GRAVES:**

- La supervisión adulta continua requerida.
- Nunca uso cerca de automóviles, calles, carreteras, callejones, áreas de piscinas, colinas, pasos, calzadas inclinadas, inclinaciones y carreteras públicas.
- Solamente un jinete a la vez.
- Use siempre los zapatos.
- Compruebe el hardware y apriete periódicamente en caso de necesidad. Reemplace inmediatamente las piezas dañadas o gastadas.
- Nunca usarlo si está lloviendo.
- Nunca usarlo de noche.
- Peso máximo **50 lbs. (22.7 kg)**.
- Este juguete no es adecuado para niños de más de **60 meses**, debido a una fuerza y tamaño insuficientes.
- No permita que los niños se paren en el carrito en ningún momento.
- Se recomienda que el conductor utilice siempre un casco adecuado que cumpla con el estándar 16 de código federal de regulaciones 1203, de la Comisión de seguridad de productos para el consumidor (CPSC) de Estados Unidos;
- **La capacidad máxima de carga de recipiente de almacenamiento es de 5 lbs. (2,25 kg). No exceda este límite ya que podría volverse inestable y peligroso.**