

## 4-In-1 Trike

model/modèle/modelo #811/#811P



Register this product at [www.radioflyer.com/register](http://www.radioflyer.com/register) for a chance to win a **Free Radio Flyer product!** (One winner selected every month!)

Thank you for your purchase. If you have any questions or comments, please visit the customer service section of our website:

Merci d'avoir acheté notre produit. Si vous avez des questions ou commentaires, veuillez référer notre site web dans la section de service à la clientèle:

Gracias por su compra. Si tiene preguntas o comentarios por favor visite la sección, servicio al cliente de nuestro website:

**www.radioflyer.com**

Or phone / ou composez le / o llame al 1-800-621-7613  
Available weekdays 8:00 a.m. to 5:00 p.m. CST.  
Please keep this sheet for future reference.  
Disponible sur semaine de 8:00 heures 17:00 heures.  
Veuillez garder cette feuille comme référence.  
De lunes a viernes de 8:00 a.m. a 5:00 p.m. CST.  
Por favor retenga esta copia para futura referencia.

Radio Flyer Inc. / 6515 West Grand Ave. / Chicago, IL 60707  
phone: 1-800-621-7613

*The Original Little Red Wagon™ - Since 1917*

### 1

Required:  
Nécessaire:  
Requeridas:

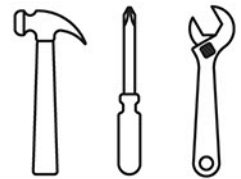

### 2

601476 (x1) 601477	100212 (x1) 110072	100213 (x1) 110037
100214/110073 (x1)	100215/110074 (x1)	100216/110075 (x1)
100217/110076 (x1)	100218 (x1)	100219/110077 (x1)
100220/110078 (x1)	100221/110079 (x1)	601481/601482 (x2)

601383/601384 (x1)



110443 (x1)

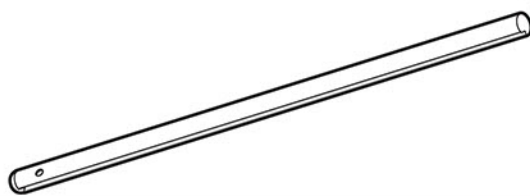

100225 (x1)

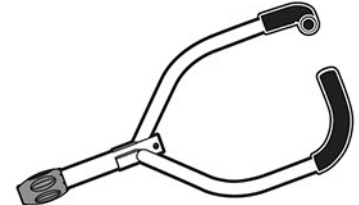

### 3

Hardware Bag:  
Sac matériel:  
Bolsa de tornillos:

100226 (x2)

M6 x 14

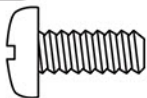

100227 (x1)

M4 X 30

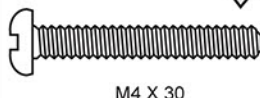

100228 (x4)

ST4.2 X 12

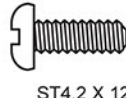

100229 (x1)

M5 X 16

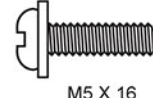

100230 (x2)

M6



100231 (x1)



10 - 24 x 2 1/8"

100232 (x1)



10-24 NYLOC

100233 (x1)



M4 NYLOC

100234 (x1)

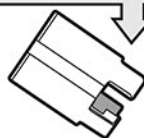

100235 (x2)

1 Extra  
1 Supplémentaire  
1 Adicional



100236 (x1)



100132 (x2)



M6  
NYLOC

100237/103102 (x2)

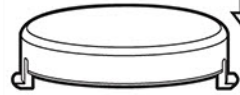

100238/11084 (x2)

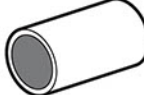

100239 (x1)



100240/110082 (x1)



100241/110083 (x1)



If you find extra hardware items, please dispose of them and keep them away from small children.

Si vous avez de éléments en surplus, rangez-les dans un endroit sur, a l'abri des bambins.

Desahcerse de la ferreteria que le sobre, manteniéndolo fuera del alcance de los niños.

## 4 ⚠️ WARNING:

### ADULT ASSEMBLY REQUIRED.

Choking hazard to children under the age of 3 years – contains small parts prior to assembly. All fasteners should be fully tightened.

Please keep instructions for future reference.

## ⚠️ AVERTISSEMENT:

### ASSEMBLAGE REQUIS PAR ADULTE.

Risque d'étouffement pour le enfants de moins de trois ans – Contient des pièces de petite taille avant assemblage. Toutes les attaches devraient être bien serrées.

Veuillez garder les instructions comme référence aux besoins.

## ⚠️ ADVERTENCIA:

### MONTAJE REQUERIDO POR ADULTOS.

Peligro de asfixia an niños menores de 3 años - contiene piezas pequeñas antes del montaje. Todos los seguros deben ser apretado s completamente.

Mantenga por favor las instrucciones para la referencia futura.

## 5

- Attach rear storage bin to frame.
- Fixez le panier arrière au cadre.
- Fije el compartimiento de carga posterior en el marco.

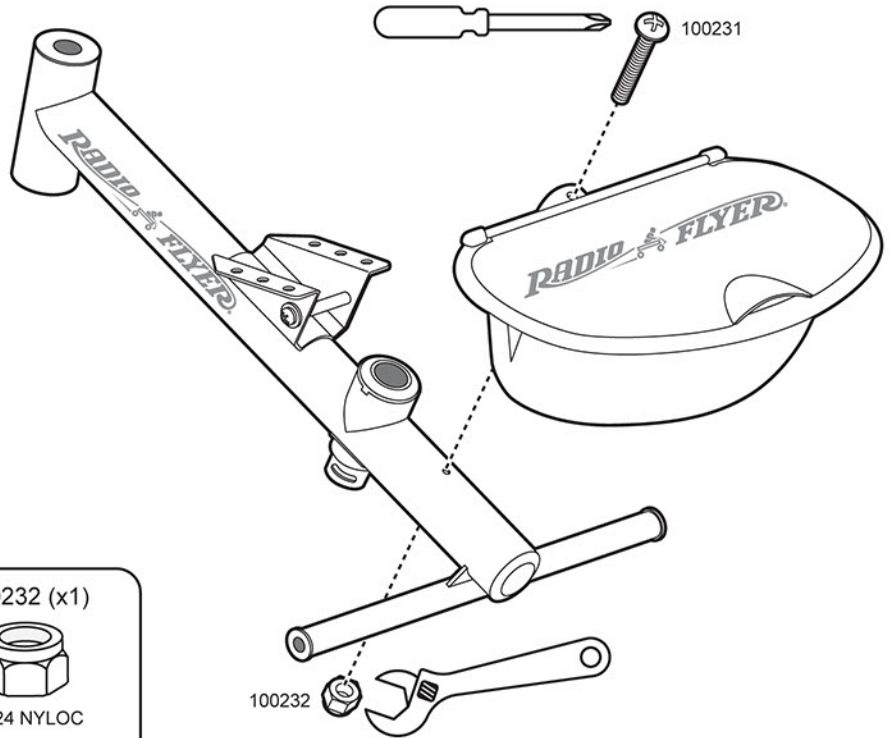
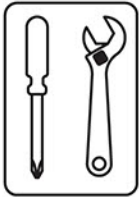

100231 (x1)

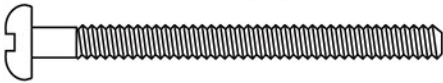

10 - 24 x 2 1/8"

100232 (x1)



10-24 NYLOC

## 6

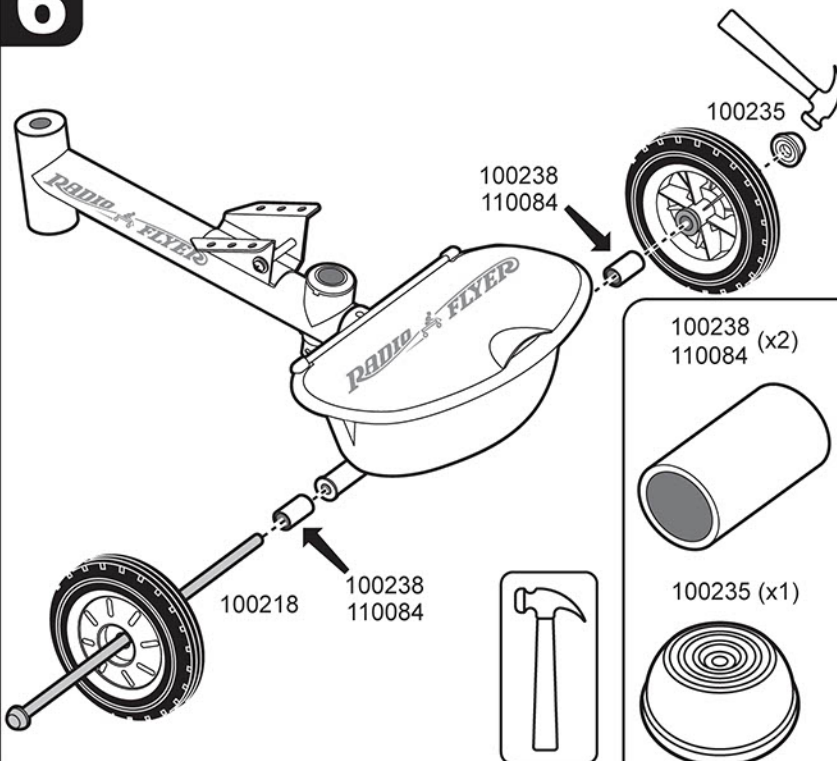

100235

100238  
110084

100238 (x2)  
110084

100235 (x1)

100218

100238  
110084

## 7

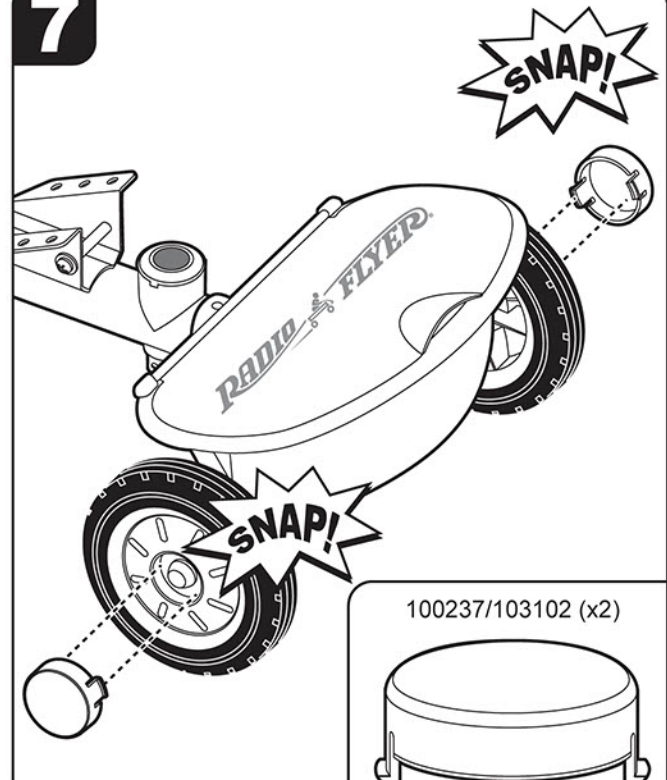

SNAP!

RADIO FLYER

SNAP!

100237/103102 (x2)

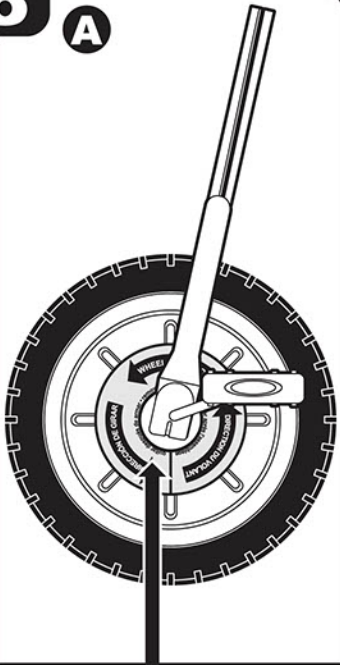
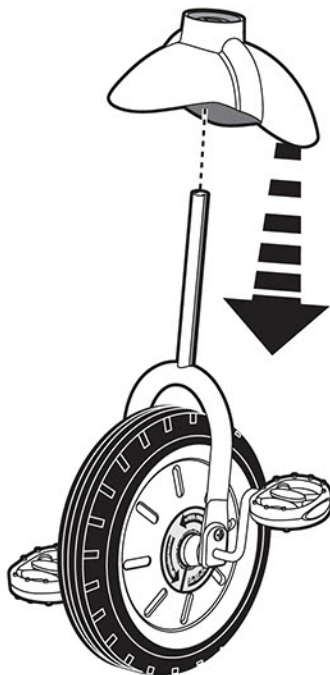
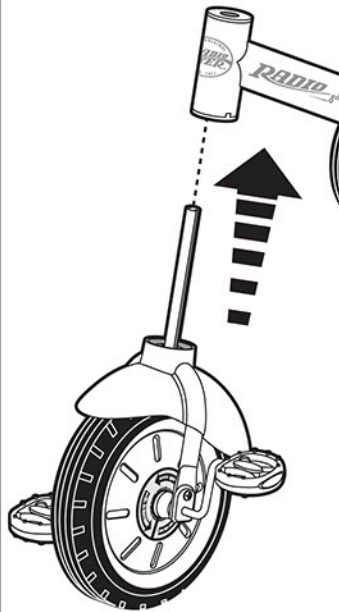
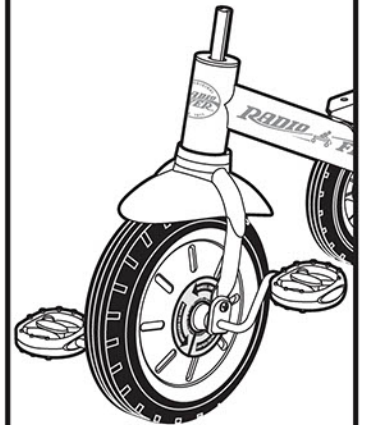

**8****A****B****C****D**

! Note: Arrows show direction of wheel rotation.

! Remarque: Les flèches sur le côté des roues indiquent la direction.

! Nota: La flecha señala la dirección de rotación de la rueda.

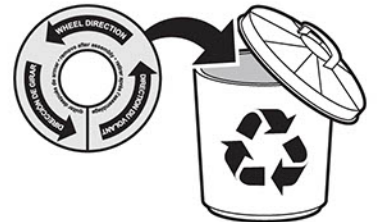
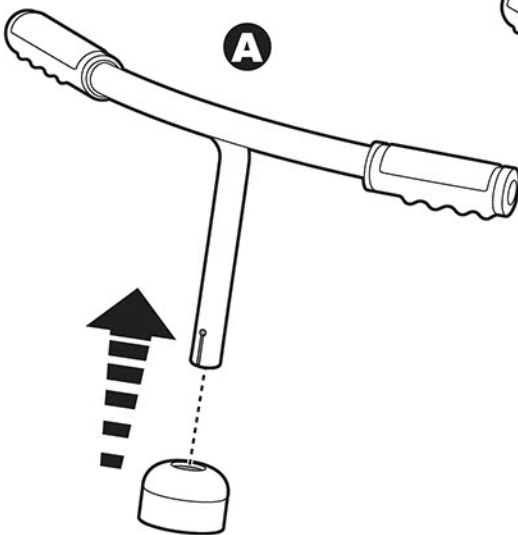
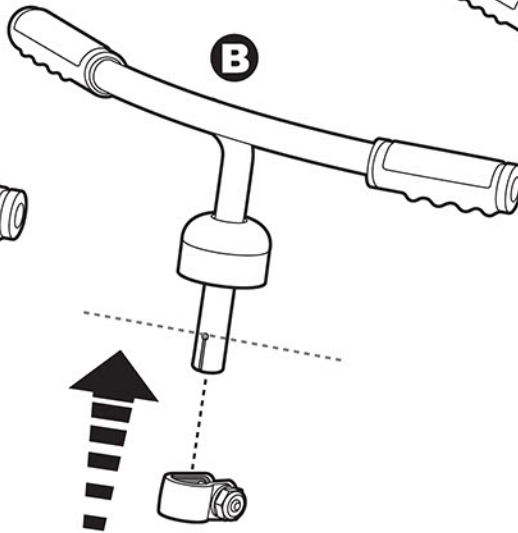
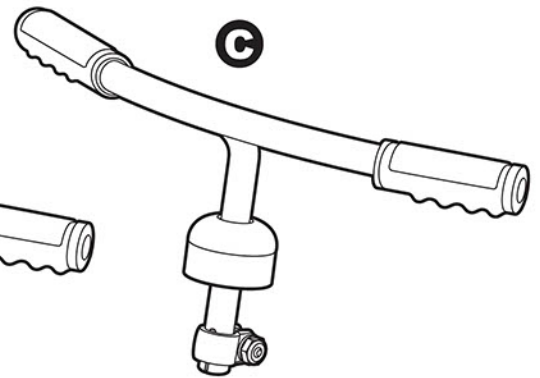
**9****A****B****C**

100239 (x1)



100236 (x1)

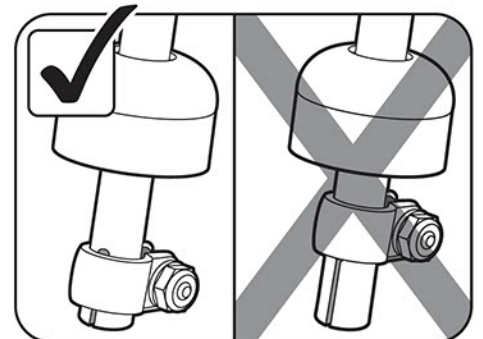

10

Make sure the handlebar is fully inserted into the stem, then tighten the fork clamp until the handlebar is secure.

Assurez-vous que la poignée de bicycle est entièrement insérée, dans la tige, serrer la bride.

Asegúrese de que el manillar este totalmente insertada en el tallo, aprieta la abrazadera de la horquilla hasta que el manillar este bien seguro.

**CAUTION:** If the handlebar is not attached properly, it could come off potentially causing a fall and/or injury.

**AVERTISSEMENT:** Si le guidon n'est pas convenablement attaché, il pourrait se détacher potentiellement causant une blessure de et/ou de chute.

**ADVERTENCIA:** Si el manillar no es conectado correctamente, podría soltarse causando potencialmente una caída y/o una herida.

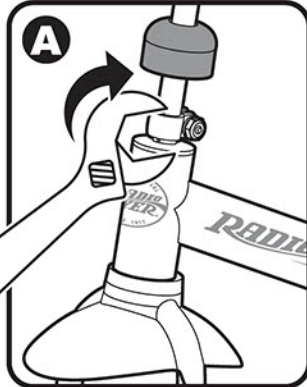
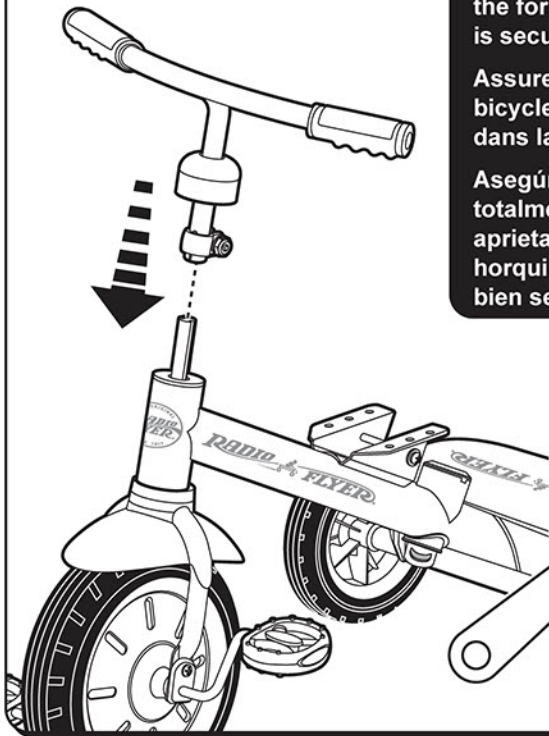

11

100213 (x1)  
110037

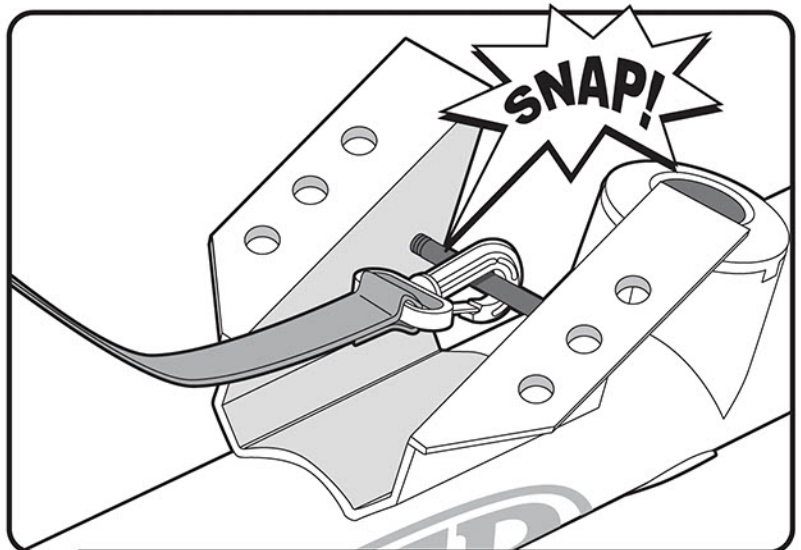
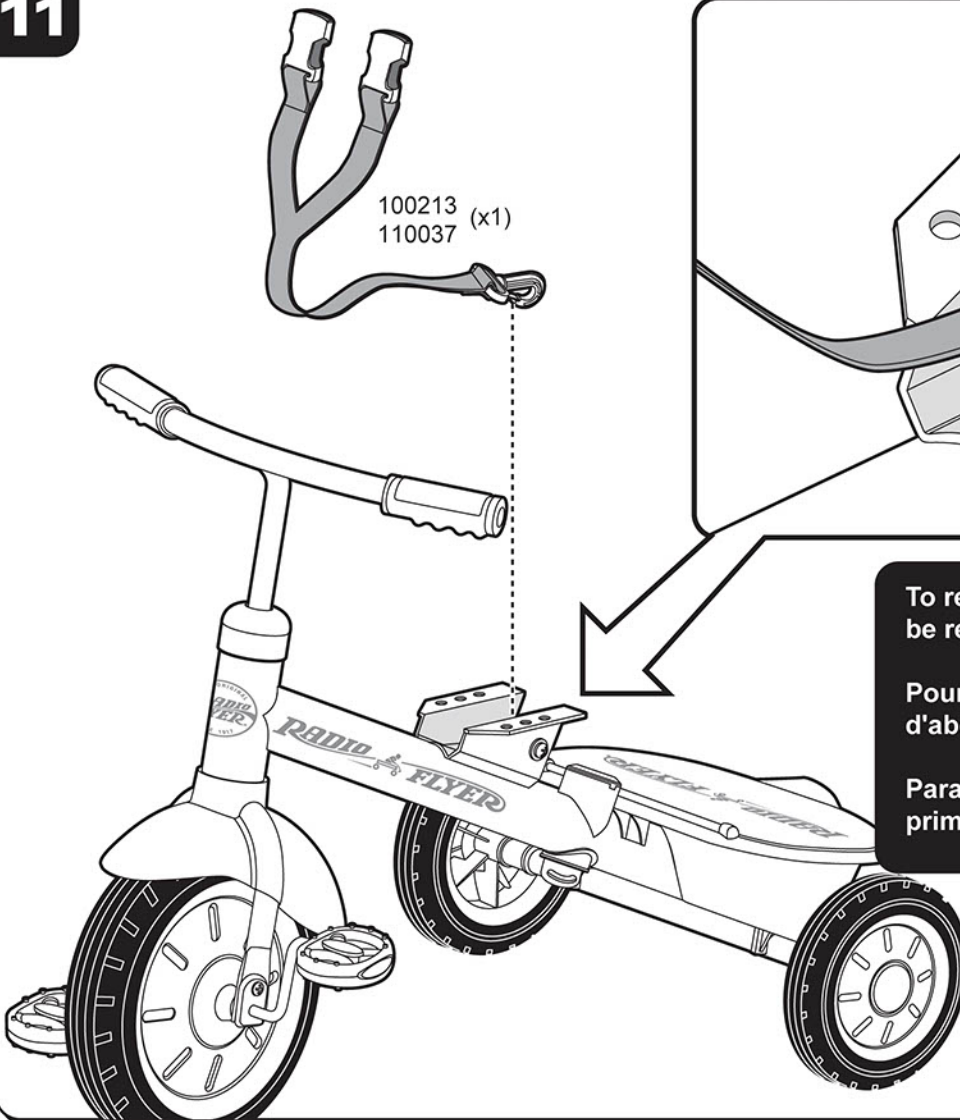

To remove the seat belt, the seat must first be removed.

Pour retirer la ceinture de sécurité, il faut d'abord enlever le siège.

Para retirar el cinturón de seguridad, primero debe retirar el asiento.

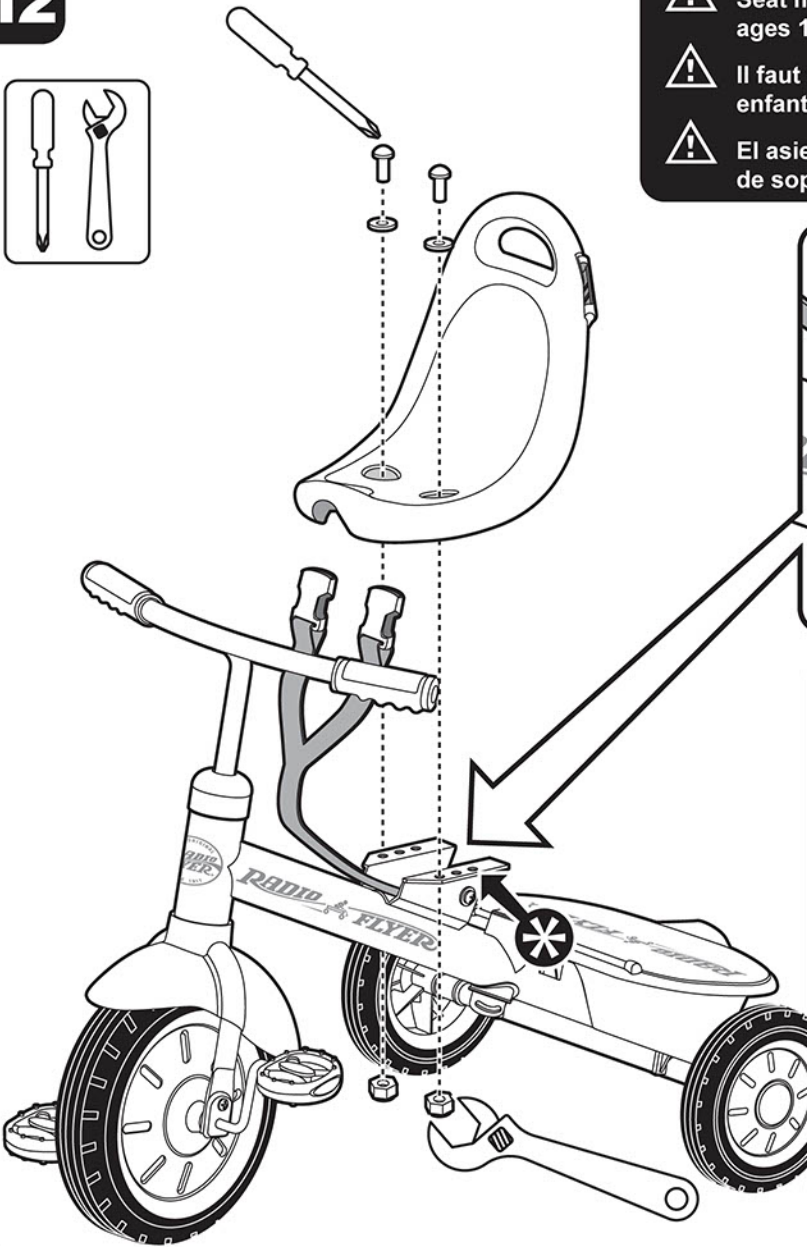
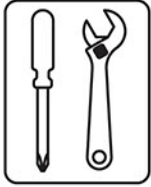

**12**

Seat must be attached in the front set of bracket holes for children ages 18 months and under.



Il faut fixer le siège dans les trous de fixation à l'avant pour les enfants âgés de 18 mois et moins.



El asiento debe estar conectado en el juego delantero de agujeros de soporte para niños de 18 meses de edad y menores.

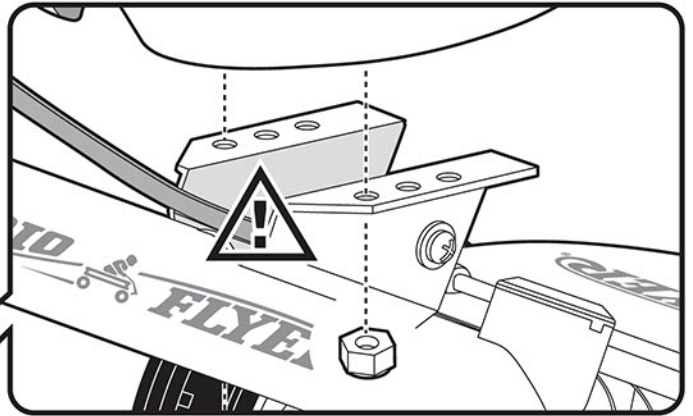

**SEAT IS ADJUSTABLE -**  
Select the most comfortable position for your child.



**ASSEYEZ EST RÉGLABLE -** choisissez la position la plus confortable pour votre enfant.



**ASINETE ES AJUSTABLE -** seleccione la posición más cómoda para su niño.

100132 (x2)



M6 NYLOC

100226 (x2)

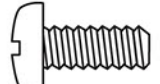

M6 x 14

100230 (x2)

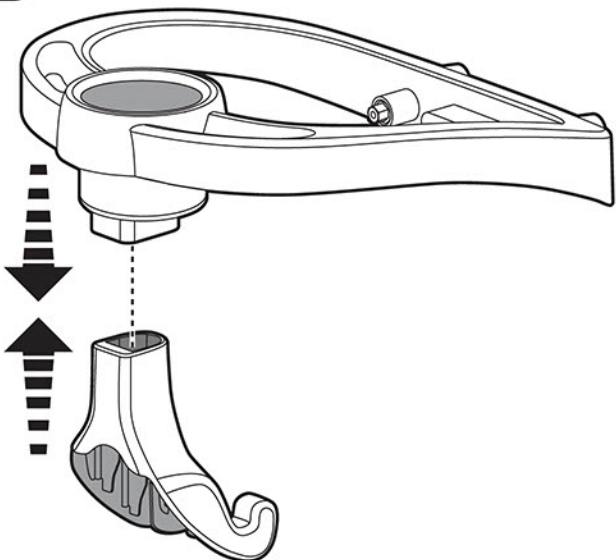

M6

**13**

Fully tighten screw.



Serrer la vis à fond.



Apriete firmemente el tornillo.

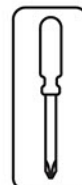

100229 (x1)

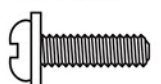

M5 X 16

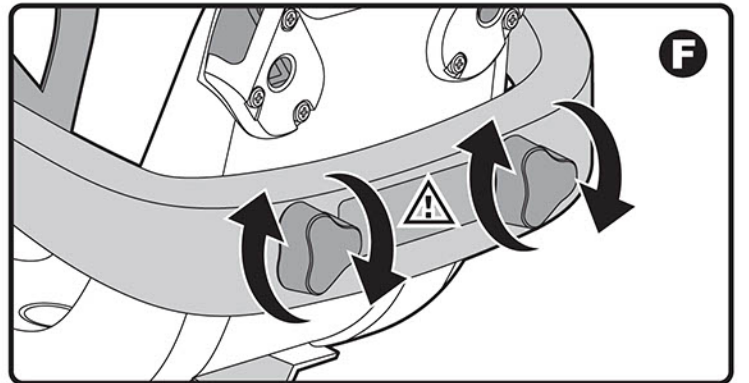
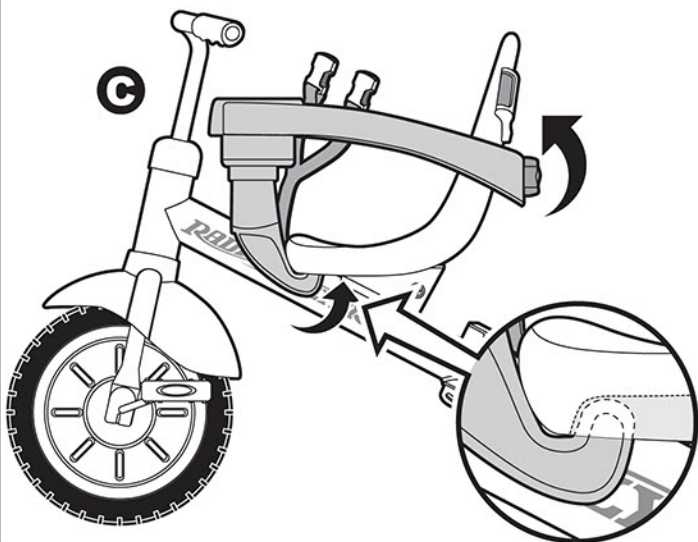
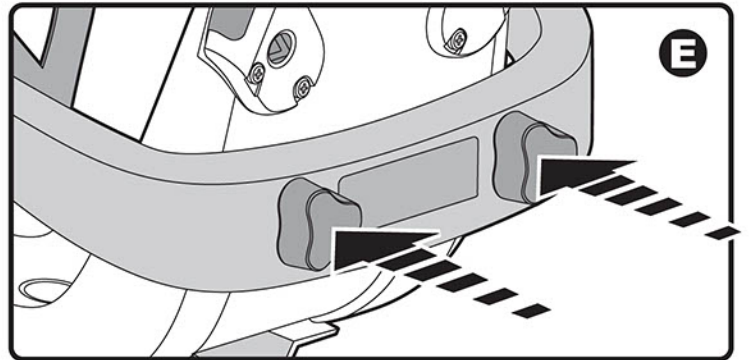
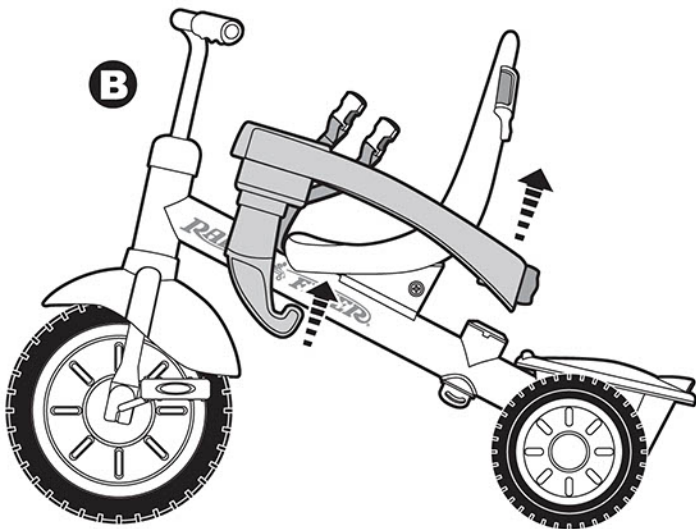
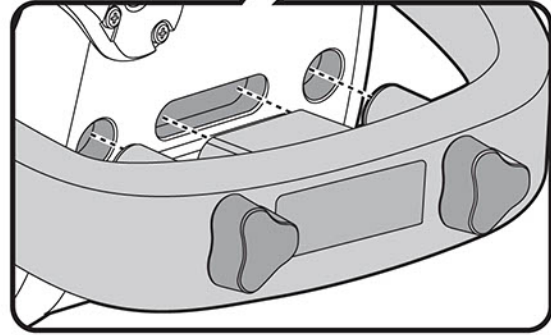
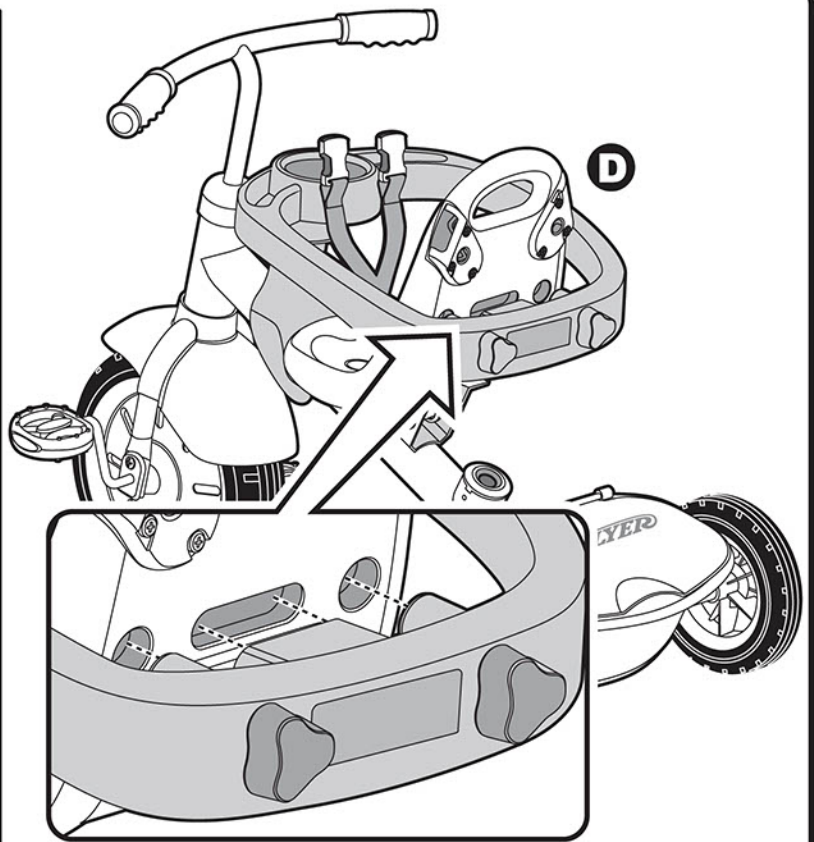
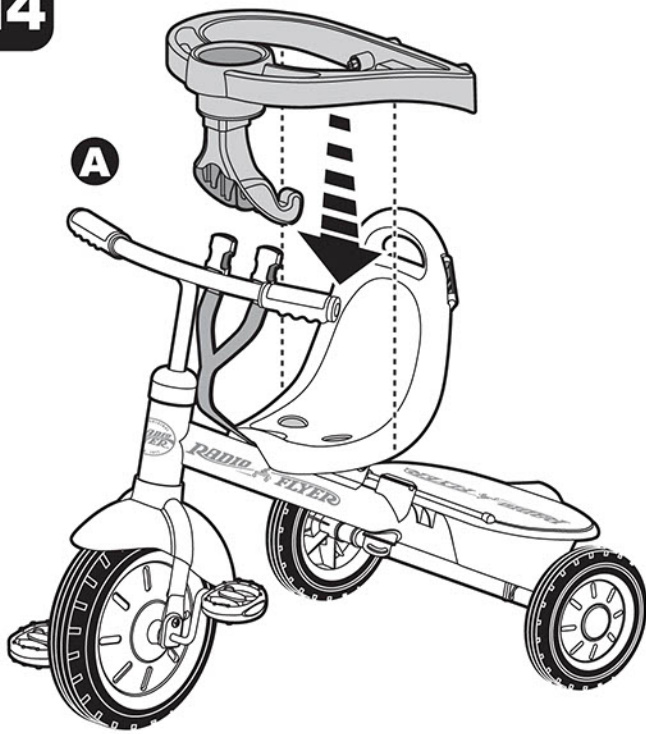

**⚠ Warning: Do not lift tricycle by the safety arms. Make sure rear knobs are fully tightened before use.**

**⚠ Avertissement: Ne levez pas le tricycle par les bras de sûreté. Avant d'utiliser, resserrez complètement les boutons amères.**

**⚠ Advertencia: No levante el triciclo por los brazos de seguridad. Asegúrese que las perillas traseras están apretadas completamente.**



15

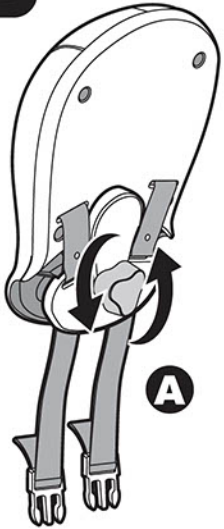

A

Unscrew  
Dévisser  
Destornille

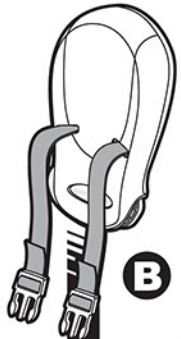

B

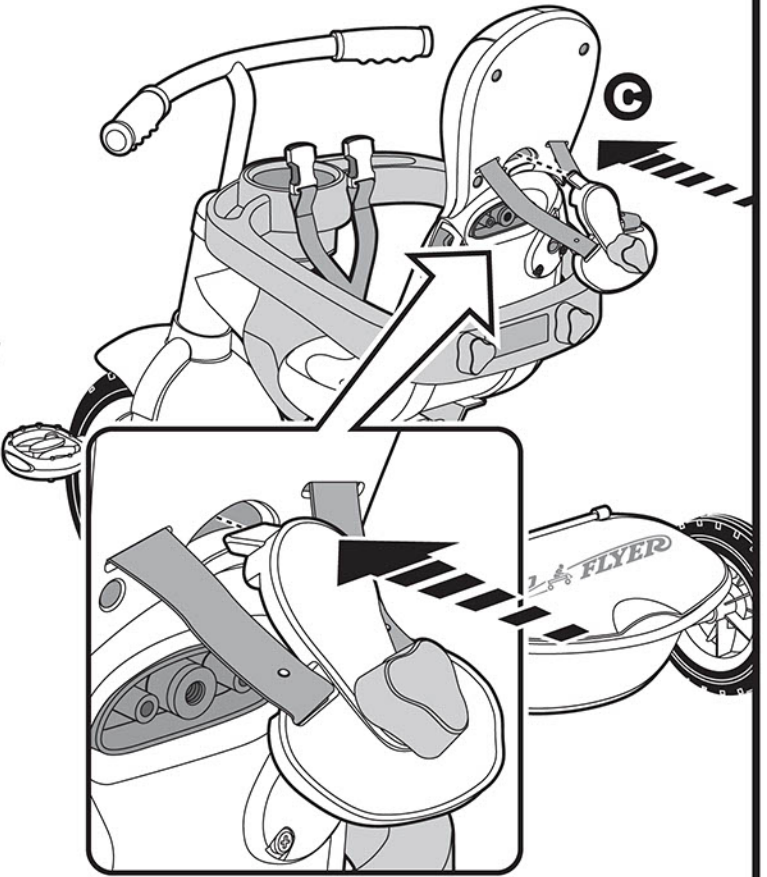
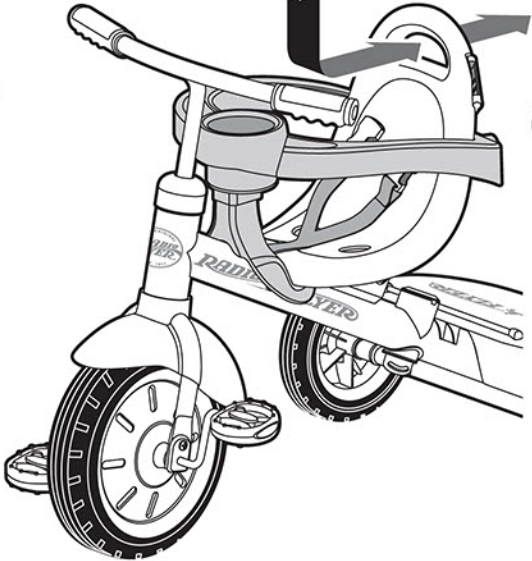

G

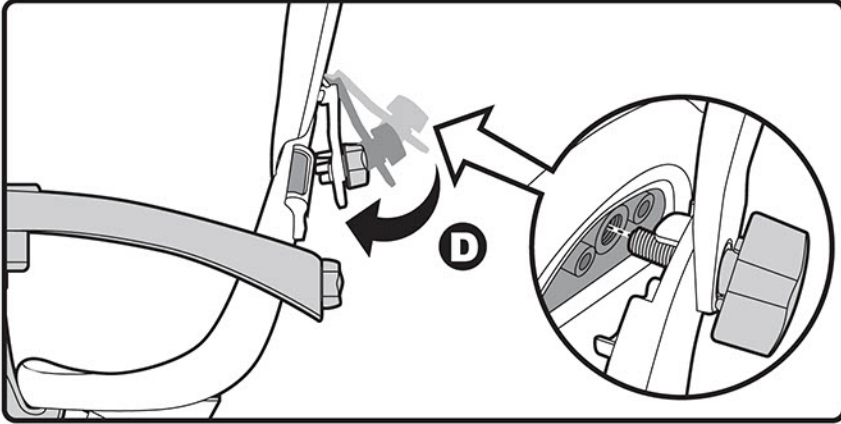

D

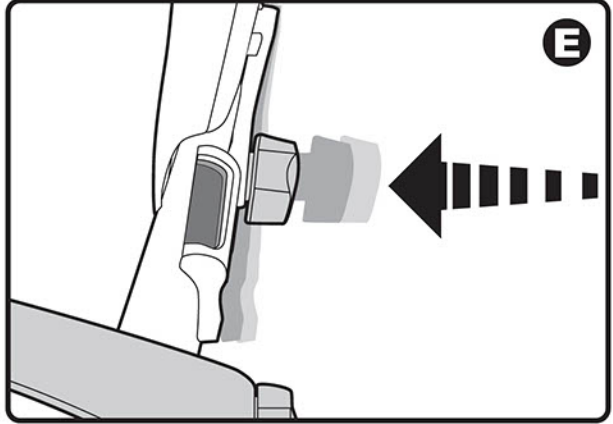

E

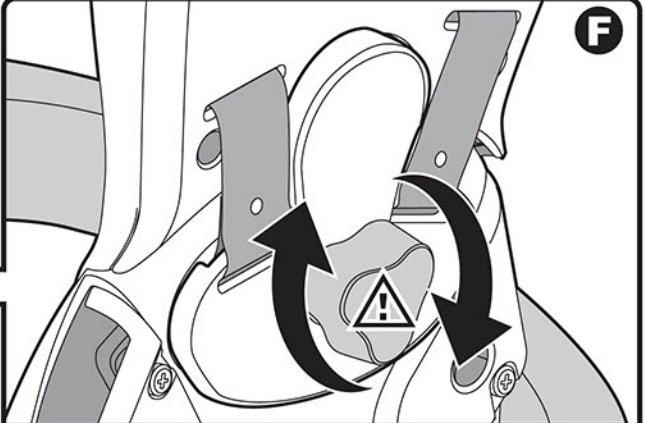
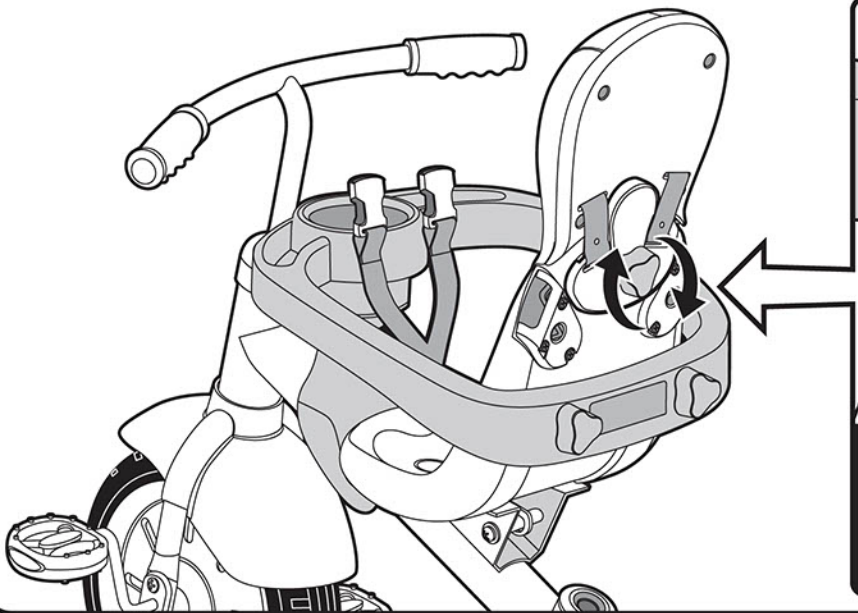

F

⚠ Fully tighten.  
⚠ Serrer à fond.  
⚠ Apriete firmemente.

16

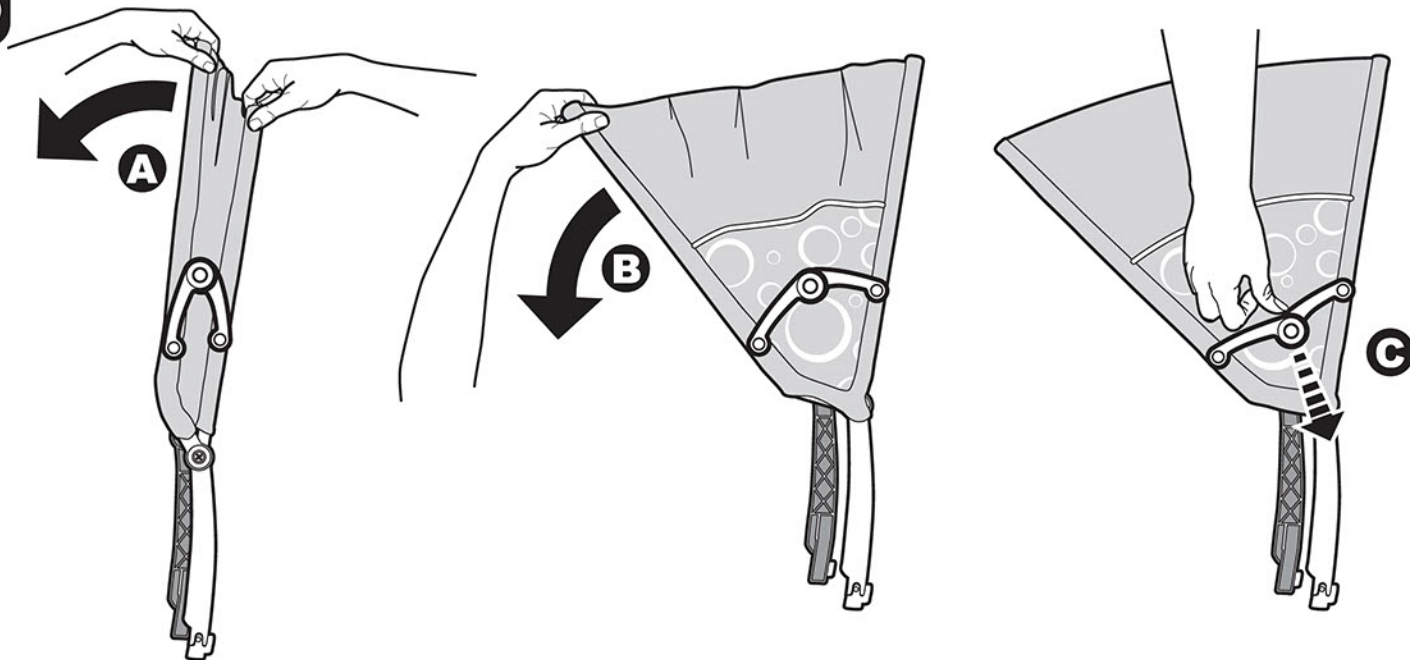

17

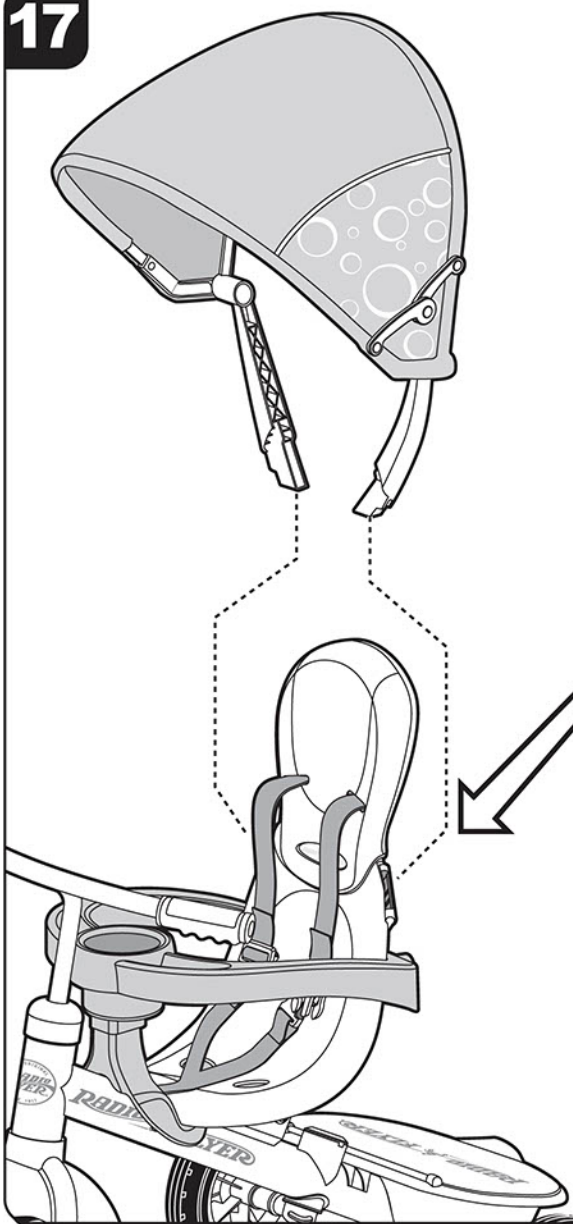

Canopy recommended only for children between 9 months and 2 years of age. Surface wash only.

Toit amovible recommandé seulement pour les enfants âgés de 9 mois à 2 ans. Lavable uniquement en surface.

Se recomienda la cubierta solo para niños entre 9 meses y 2 años de edad. Solo lave superficialmente.

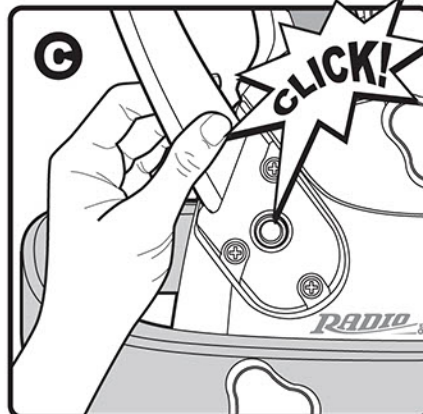
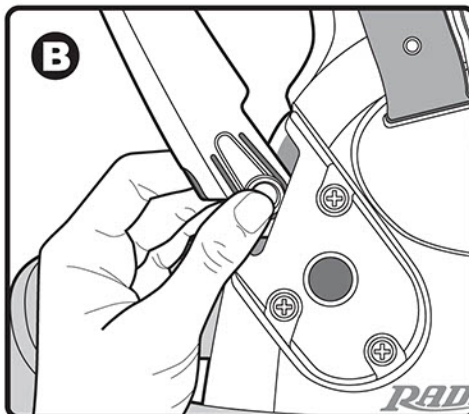
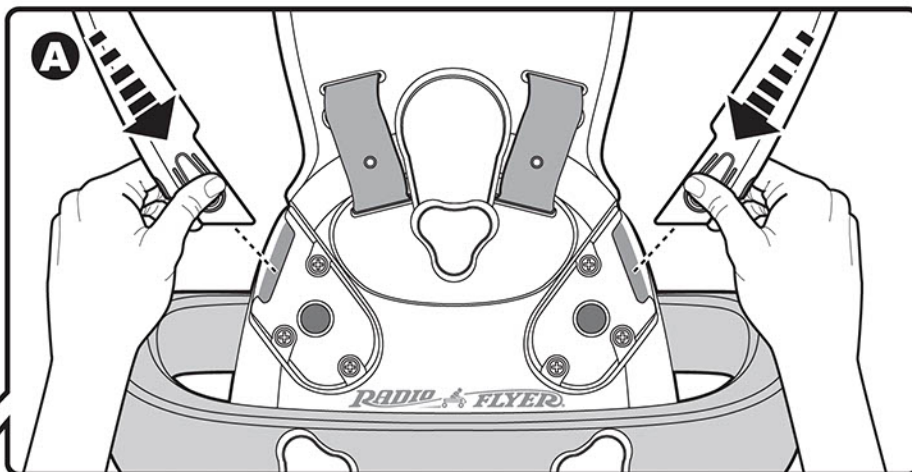



# 18

To Remove Canopy:

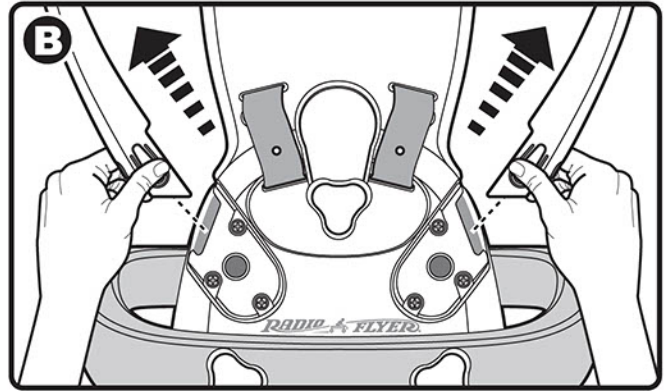
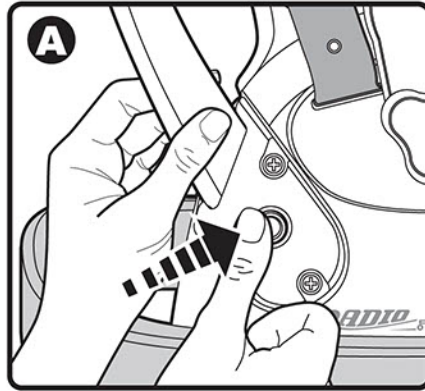

Pour retirer le toit amovible:

Para retirar la cubierta:

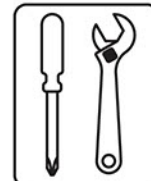
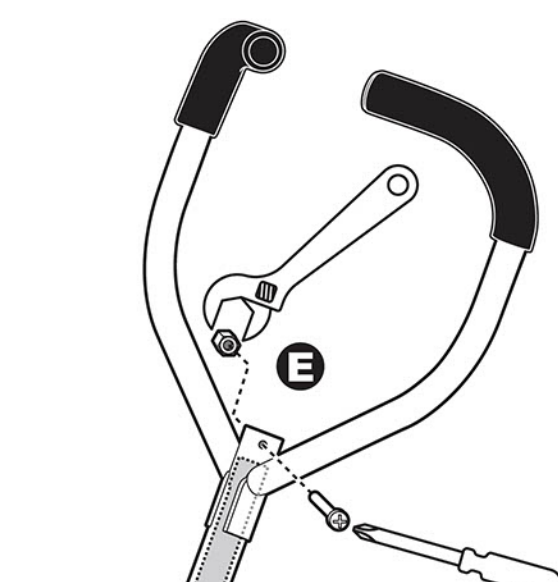
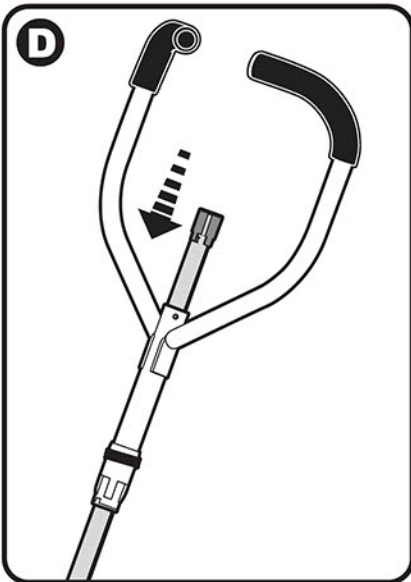
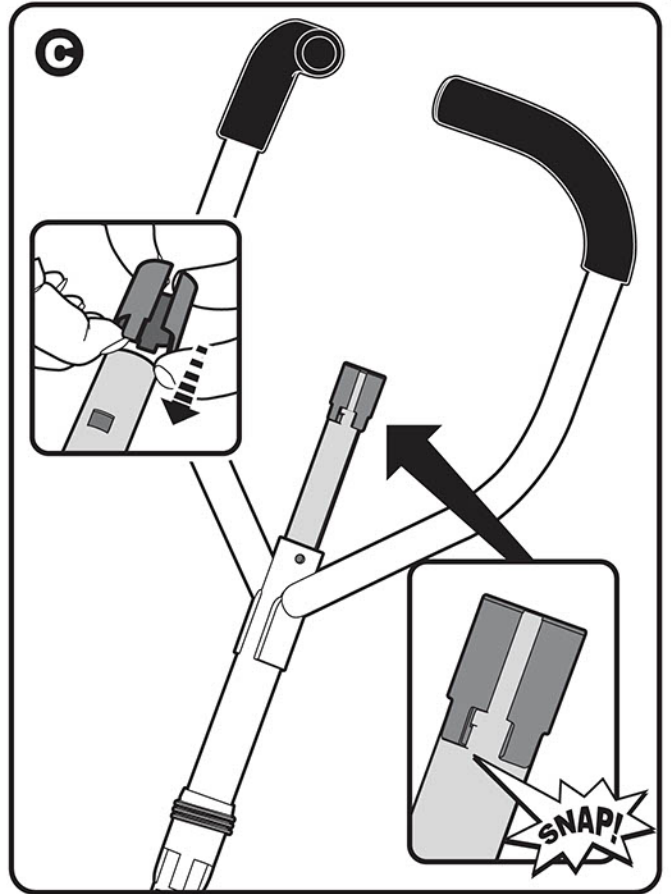
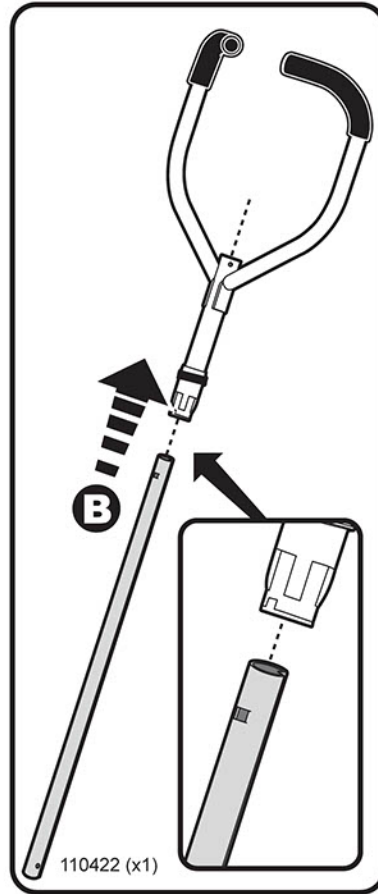
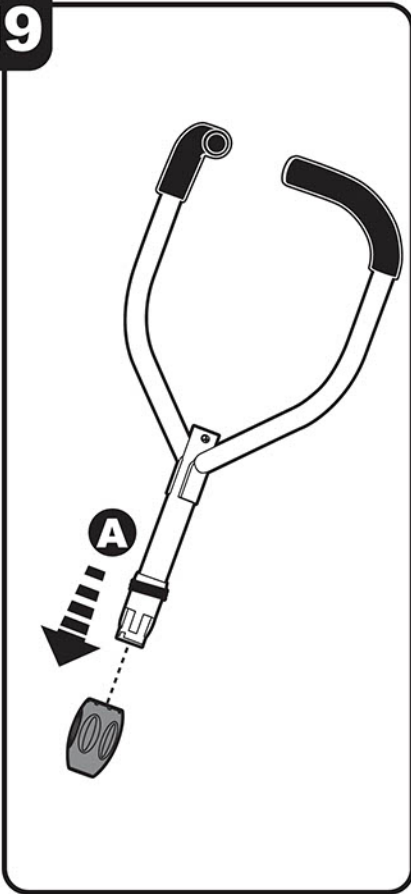

# 19



- 100227 (x1)  
  
M4 X 30
- 100233 (x1)  
  
M4 NYLOC

20

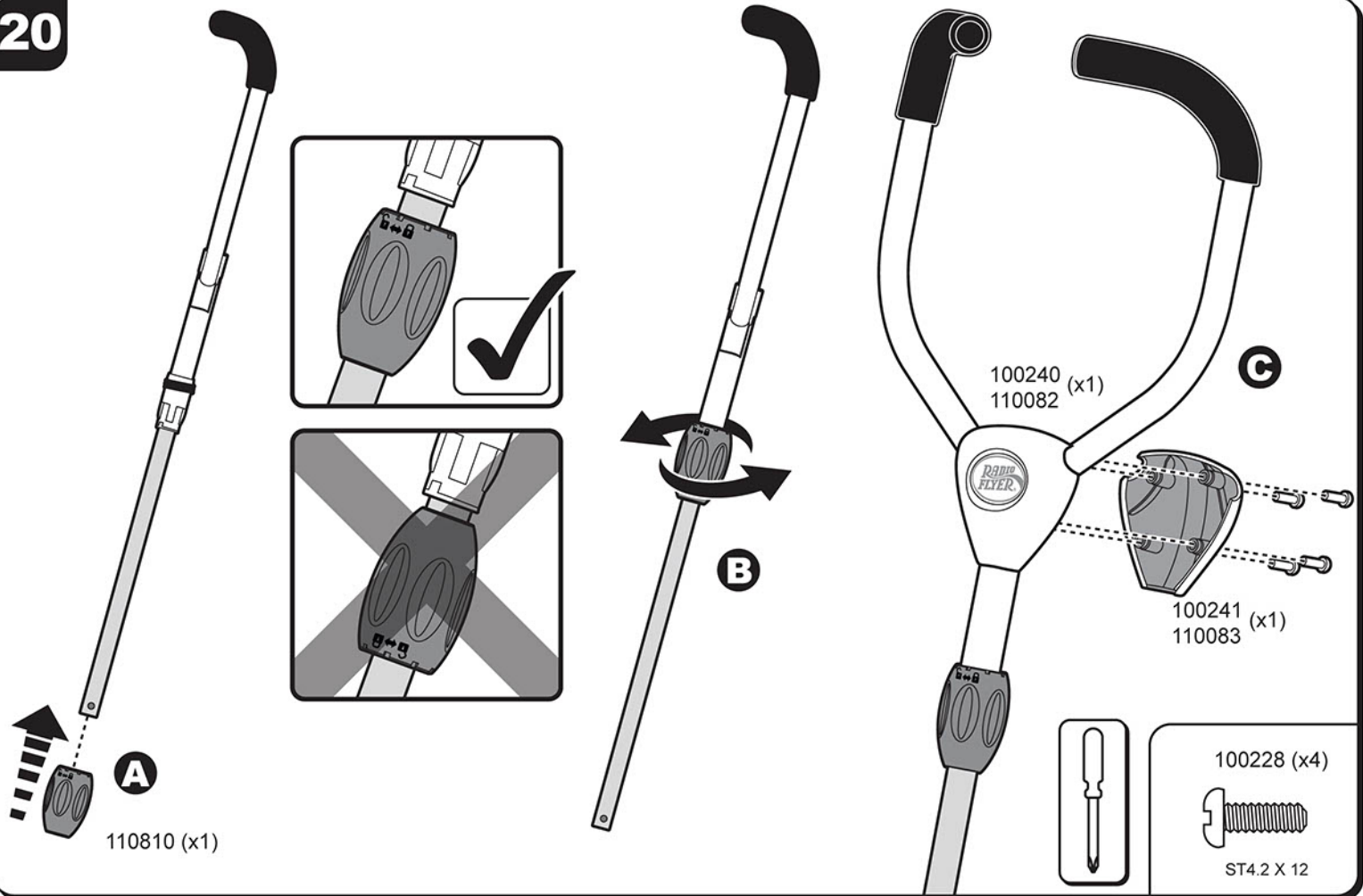

**21** **WARNING:**

Transporting a child in a tricycle up or down stairs may lead to falls and possible serious injury. Push handle is not intended to support weight of tricycle and rider. Child must be removed from tricycle before transporting up or down stairs.

**AVERTISSEMENT:**

Transporter un enfant sur un tricycle dans des escaliers peut provoquer une chute ou des blessures sérieuses. La poignée de manœuvre n'est pas conçue pour supporter le poids du tricycle et du conducteur. L'enfant ne doit pas rester sur le tricycle avant de monter ou descendre des escaliers.

**ADVERTENCIA:**

Subir o bajar a un niño por una escalera mientras esta montado en el triciclo puede provocar caídas o lesiones graves. La barra guía no está diseñada para aguantar el peso del triciclo y del ocupante. El niño debe desmontar del triciclo antes de subir o bajar por una escalera.

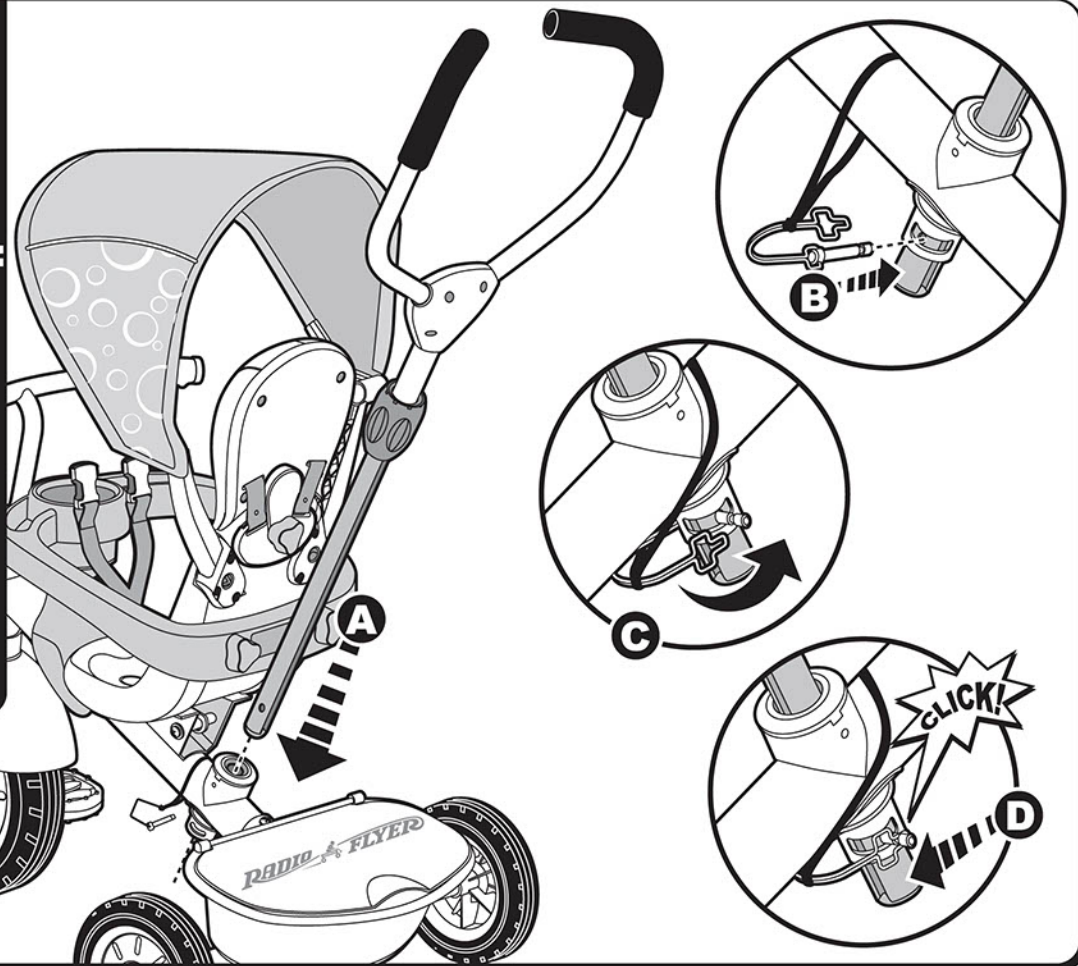



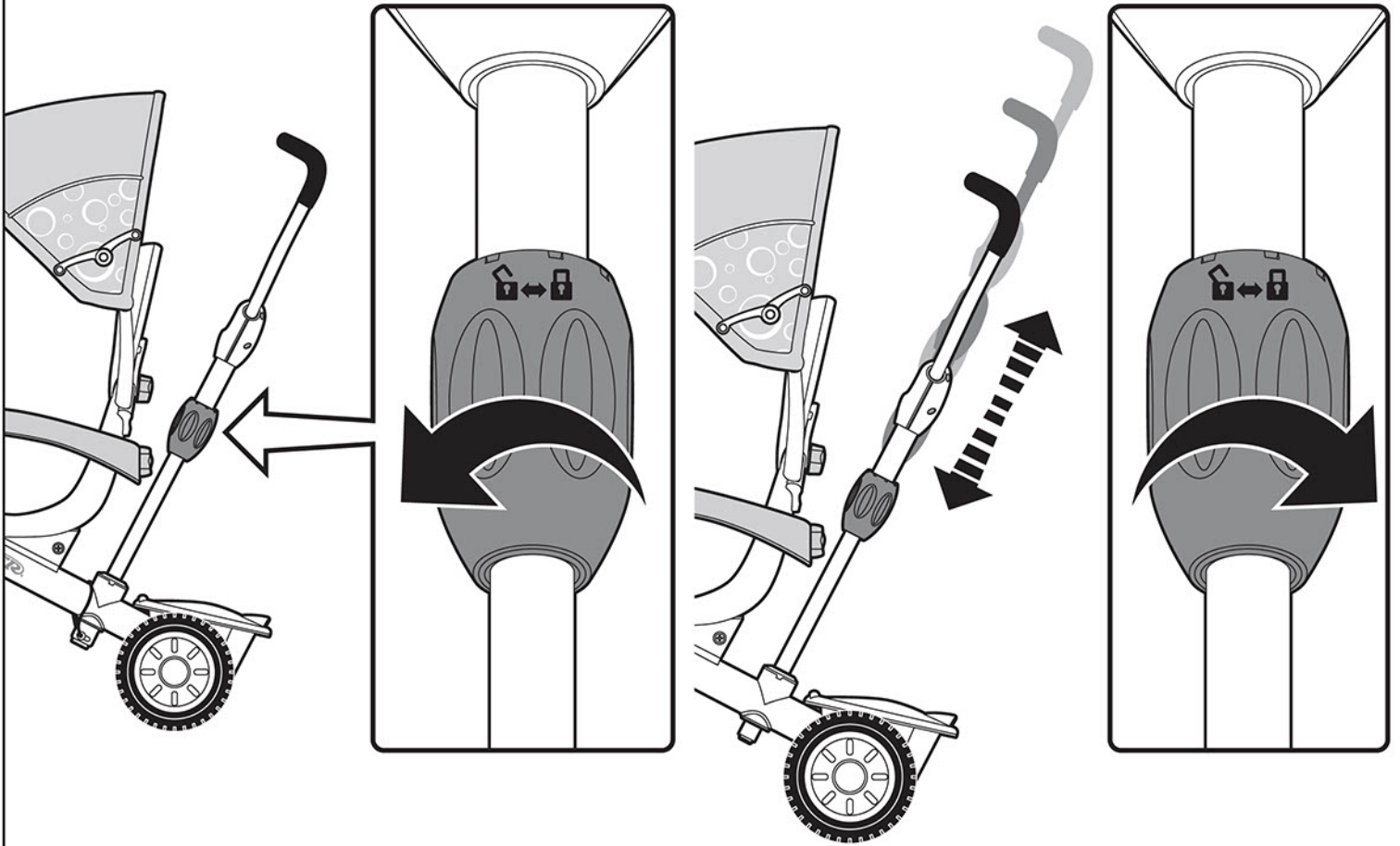

**23** Securing a child in the tricycle.  
 Attacher un enfant dans le tricycle.  
 Asegurando un niño en el triciclo.

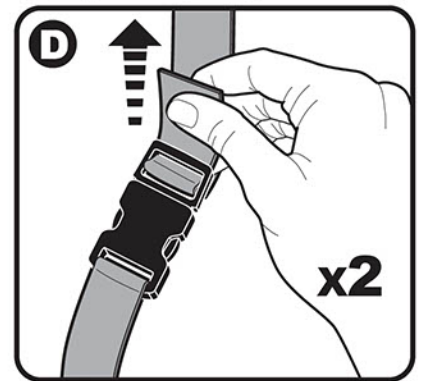
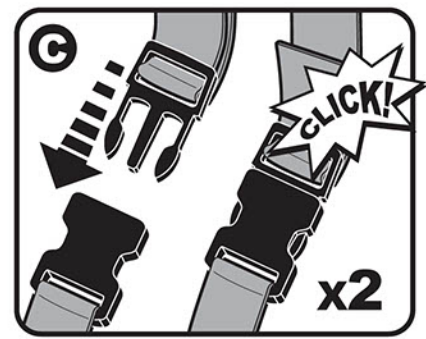
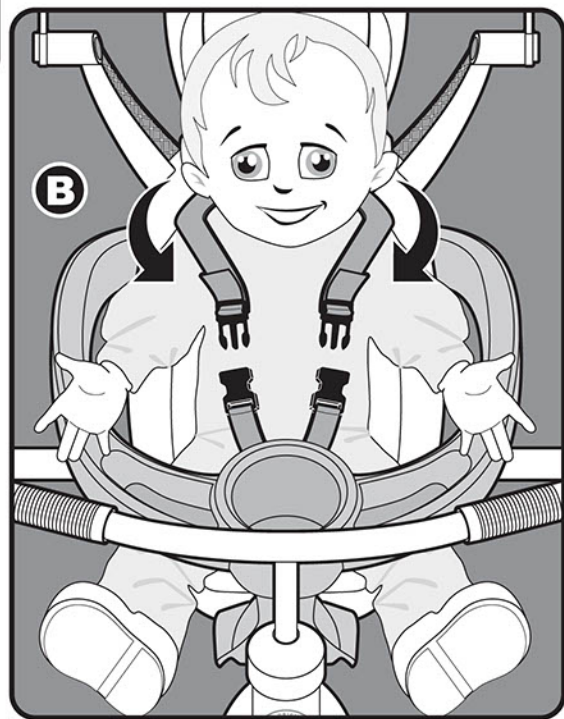
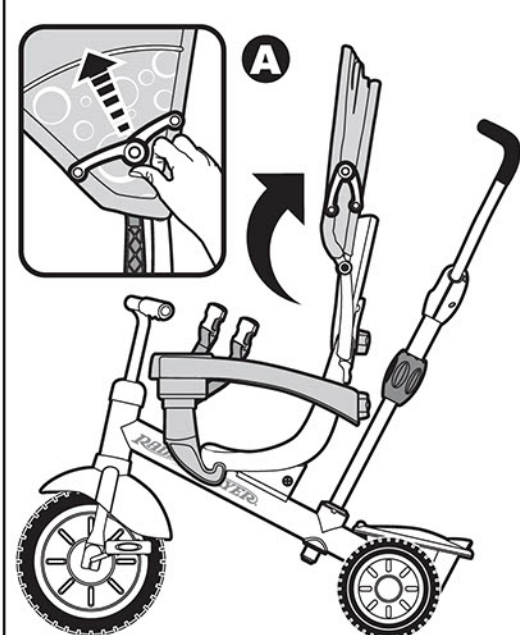





### 9 months – 18 months

- All accessories attached.
- Canopy on or off.
- Seat must be attached in 1st set of bracket holes (closest to handlebar).

### 9 mois à 18 mois

- Tous les accessoires fixés.
- Toit amovible en place ou enlevé.
- Le siège doit être fixé dans la 1re série de trous du support (la plus proche du guidon).

### Desde 9 a 18 meses

- Incluye todos los accesorios.
- Cubierta colocada o retirada.
- El asiento debe estar conectado en el primer juego de agujeros del soporte (más cerca del manubrio ajustable).



### 18 months – 2 years

- Safety arms removed. (We recommend removing the push bar and canopy before detaching the safety arms)
- Canopy on or off.
- We recommend seat in first set of bracket holes.

### 18 mois à 2 ans

- Bras de sécurité enlevés. (Nous vous recommandons de retirer la barre de poussée et le toit amovible avant de détacher les bras de sécurité).
- Toit amovible en place ou enlevé.
- Nous recommandons de fixer le siège dans la 1re série de trous du support.

### Desde 18 meses a 2 años

- Brazos de seguridad retirados. (Recomendamos la barra de empuje y la cubierta antes de separar los brazos de seguridad).
- Cubierta colocada o retirada.
- Recomendamos el asiento en el primer juego de agujeros de soporte.



### 2 years – 3 years

- Push bar attached.
- Seat belts removed.
- Head rest removed.
- Canopy removed.
- Seat in 1st or 2nd set of bracket holes (Adjust to size of child).

### 2 ans à 3 ans

- Barre de poussée fixée.
- Ceintures de sécurité enlevées.
- Appui-tête enlevé.
- Toit amovible enlevé.
- Siège dans la 1re ou 2e série de trous du support (Ajuster selon la taille de l'enfant).

### Desde 2 a 3 años

- Barra de empuje conectada.
- Cinturones de seguridad retirados.
- Apoyacabeza retirado.
- Cubierta retirada.
- Asiento en el primer o segundo juego de agujeros de soporte (Ajustar al tamaño del niño).

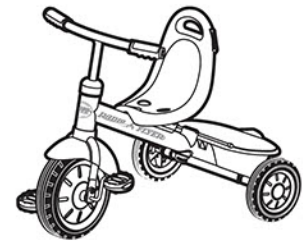

### 3 years – 5 years

- Accessories removed.
- Seat in 2nd or 3rd set of bracket holes (Adjust to size of child).

### 3 ans à 5 ans

- Tous les accessoires enlevés.
- Siège dans la 2e ou 3e série de trous du support (Ajuster selon la taille de l'enfant).

### Desde 3 a 5 años

- Todo retirado.
- Asiento en el segundo o tercer juego de agujeros de soporte (Ajustar al tamaño del niño).



## WARNING:

### TO AVOID SERIOUS INJURY:

#### For ages 9 months to 5 years.

- Continuous adult supervision required.
- Never use near motor vehicles.
- Never use near streets, swimming pools, hills, steps, or sloped driveways;
- Always wear shoes when using the tricycle.
- Never allow more than one rider.
- We recommend riders always wear a properly fitted helmet that complies with U.S. Consumer Product Safety Commission (CPSC) Standard 16 CFR 1203.
- Maximum loading capacity of rear bin is 5.0 lb (2.3 kg). Excessive weight may cause a hazardous or unstable condition.
- Do not step or ride in rear bucket.
- Maximum Weight: 49.0 lbs (22.2 kg).
- Make certain that anyone who uses this tricycle has been fully instructed in its operation.
- Ensure that an adult has followed the assembly instructions to ensure the tricycle is assembled properly.
- Do not lift tricycle by the safety arms.
- Make sure knobs on safety arm and headrest are fully tightened before use.
- Skill is required to avoid falls or collision.



## AVERTISSEMENT:

### POUR ÉVITER TOUTE BLESSURE GRAVE:

#### Pour les enfants ages entre 9 mois et 5 ans.

- Supervision continue par un adulte requise.
- Ne jamais utiliser près des véhicules à moteur.
- Ne jamais utiliser à proximité des rues, des piscines, des collines, des escaliers ou des passages en pente.
- Toujours porter des chaussures pour l'utilisation du tricycle.
- Ne jamais autoriser plus de une conducteur.
- Tout utilisateur doit porter un casque protecteur approprié conformément au règlement 16 CFR 1203 de l'U.S. Consumer Product Safety Commission (CPSC).
- Charge maximale pour le compartiment arrière: 2.3 kg (5.0 lb). Le poids excessif peut causer une condition hasardeuse ou instable.
- Pas l'étape ou voyager dans le seau postérieur.
- Poids maximum: 22.2 kg (49.0 lb).
- Veuillez vous assurez que tout utilisateur de ce tricycle reçoit.
- S'assurer qu'un adulte suit les instructions de montage afin d'assurer un assemblage correcte.
- Ne levez pas le tricycle par les bras de sûreté.
- Veiller à ce que les boutons retenant le bras de sécurité et l'appui-tête soient serrés à fond avant utilisation.
- Il faut une certaine habileté pour éviter les chutes et les collisions.



## ADVERTENCIA:

### PARA EVITAR LESIONES GRAVES:

#### Para niños de 9 meses a 5 años.

- Se requiere la supervisión continua de un adulto.
- Nunca utilice cerca de los vehículos de motor.
- Nunca utilice cerca de calles, piscinas, colinas, escaleras o cocheras con bajada.
- Siempre usar zapatos cuando se utilice el triciclo.
- Nunca permita más de uno piloto.
- Se recomienda que el conductor utilice siempre un casco adecuado que cumpla con el estándar 16 de código federal de regulaciones 1203, de la Comisión de seguridad de productos para el consumidor (CPSC) de Estados Unidos.
- La capacidad máxima de carga en la caja trasera es de 2.3 kg (5.0 lb). Exceso de peso es peligroso y puede causar condiciones inestables.
- No se suba o pise el compartimento de carga.
- El peso máximo: 22.2 kg (49.0 lb).
- Asegúrese de que la persona que use este triciclo este bien informado de su operación.
- Seguir las instrucciones de ensamble para asegurarse de que el triciclo este propiamente armado.
- No levante el triciclo por los brazos de seguridad.
- Asegurarse de que las perillas en el brazo de seguridad y el apoyacabeza estén completamente apretadas antes de usar.
- La habilidad de manejo se requiere para evitar caídas o colisiones.

#### MAINTENANCE INSTRUCTIONS:

1. Oil or grease moving parts periodically. 2 Check nuts and bolts often and tighten if necessary. Make certain hand grips are in place. 3. Any parts showing evidence of wear should be replaced immediately. 4. Follow closely the assembly instructions pertaining to the proper adjustment of handle bar and seat. 5. It is the responsibility of the adult who assembles this tricycle to properly install all parts included in the factory sealed shipping carton and to make adjustments to the functional parts such as handle bar and seat when necessary. These instructions are valuable. It will assure your being able to obtain proper parts service at all times. We suggest you keep it with other valuable papers.

#### INSTRUCTIONS D'ENTRETIEN:

1. Lubrifiez les pièces mobiles périodiquement. 2. Vérifier les filets et boulons régulièrement et serrer si nécessaire. Assurez-vous que les poignées sont bien en place. 3. Toutes pièces usées avec une apparence de faiblesse devraient être remplacées au plutôt. 4. Suivre les instructions d'assemblage concernant les ajustements pour les poignées et le siège. 5. C'est la responsabilité de l'adulte qui monte le tricycle d'installer toutes les parties contenues dans la boîte fermée hermétiquement de façon appropriée et de faire les ajustements nécessaires aux pièces telle que les poignées et le siège. Ces instructions sont importants et vous aiderons à obtenir des pièces appropriées en tout temps. Nous vous suggérons de garder ces instructions avec autres papiers de valeur comme référence.

#### INSTRUCCIONES DE MANTENIMIENTO:

1. Lubricar todas las piezas móviles periódicamente con aceite o grasa. 2. A menudo examinar los tornillos y las tuercas apretándolos cuando sea necesario. Asegúrese también de que los punos estén siempre en su sitio correcto. 3. Reemplazar inmediatamente toda pieza que muestre evidencia de desgaste excesivo. 4. Seguir cuidadosamente las instrucciones de armado respecto a la debida graduación del manubrio y el asiento. 5. Es la responsabilidad del adulto que va armar el triciclo de instalar apropiadamente todas las partes incluidas en la caja sellada de fabrica y hacer los ajustes necesarios del manubrio y el asiento cuando sea necesario. Estas instrucciones son valiosas, aseguran de que usted pueda obtener apropiado servicio de piezas en todo momento. Le sugerimos que mantenga las instrucciones con sus otros papeles valiosos.